

# SPEEDMASTER Installation Instructions



## AI85086 SpeedMaster™ Installation Instructions for SuperNine®

### INSTALLATION

- A. Slide completed module into the insert cavity, making sure to align the module polarization keys with the cavity keyway. (Figure 1)
- B. Using the retention ferrule tool (Glenair P/N 607-011), and a 3/8" wrench, tighten the outer shield ferrule to a torque of 8-10 in-lb. (Figure 2)
- C. Install remaining modules in the same manner (figure 3)

#### Notes:

Figures 1-3 show installation into a SuperNine 25-7 plug. Glenair recommends starting with the center module for arrangement 25-7.

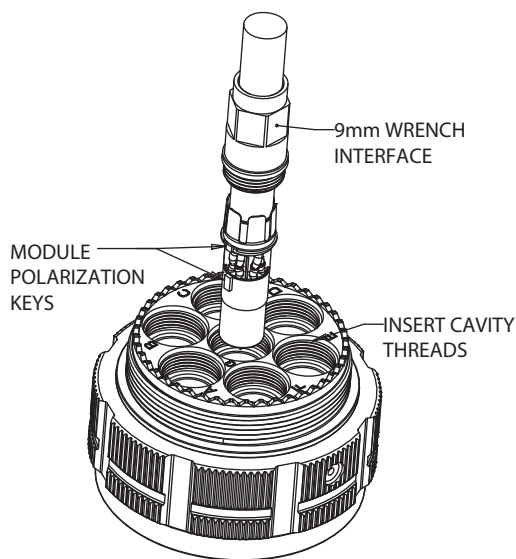

FIGURE 1

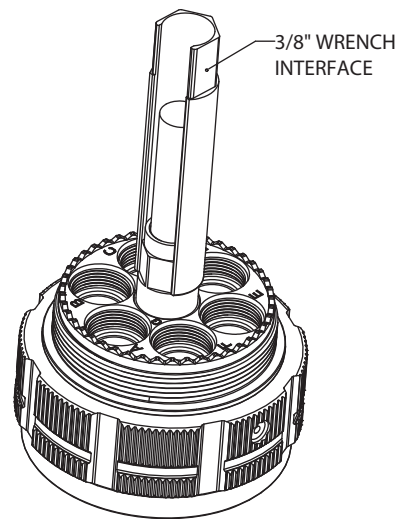

FIGURE 2

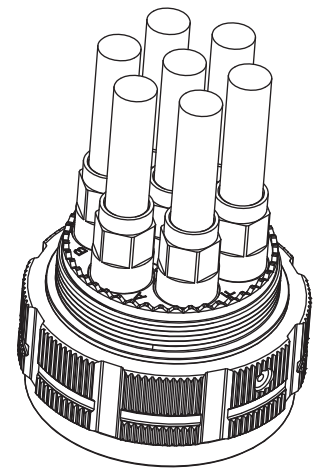

FIGURE 3