

SPEEDMASTER Installation Instructions



AI85087 SpeedMaster™ Installation Instructions for Mighty Mouse 824

INSTALLATION

- A. Slide completed module into the insert cavity, making sure to align the module polarization keys with the cavity keyway. (Figure 1)
- B. Using a 9mm wrench or the retention ferrule tool (Glenair P/N 607-011), tighten the outer shield ferrule to a torque of 8-10 in-lb. (Figure 2)
- C. Install 809SL060-3 shrink boot onto rear of shell. (Figure 3)

Notes:

Figures 1-3 show installation into a 824-010-01 shell. Installation in all other Mighty Mouse SpeedMaster connectors is identical.

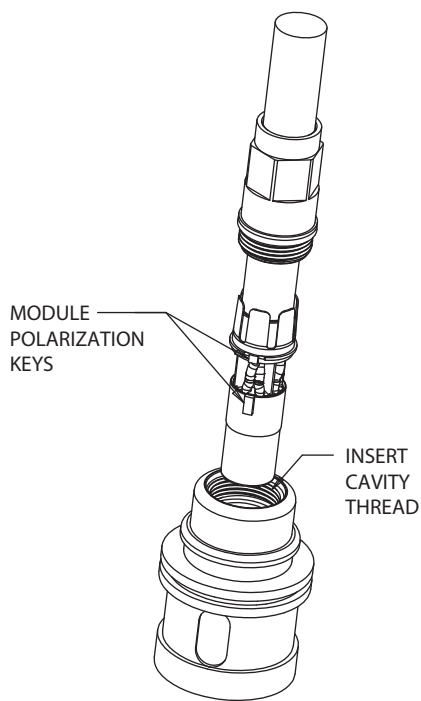

FIGURE 1

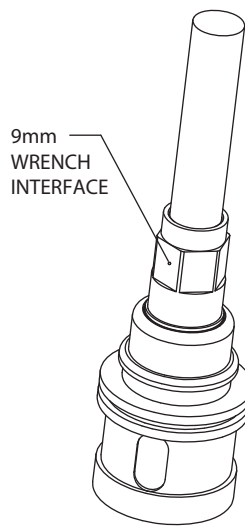

FIGURE 2

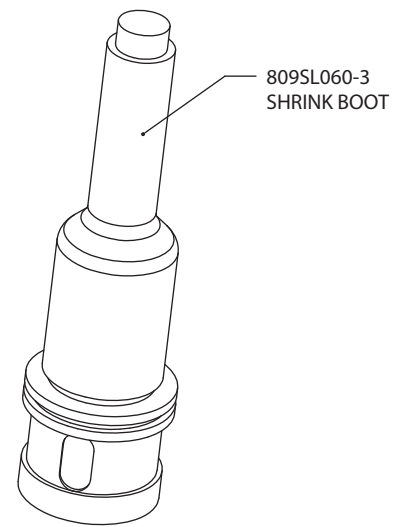

FIGURE 3