

061-009

Light-duty pin pushers and pullers

12 lb. pull force

Non-redundant circuit



A

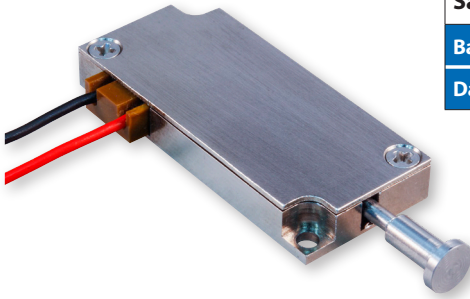

NON-REDUNDANT CIRCUIT PIN PULLER MECHANISM, LIGHT-DUTY

How To Order		
Sample Part No.	061	-009
Basic Part No.	Light-Duty Pin Puller	
Dash No.	Non-Redundant Circuit	

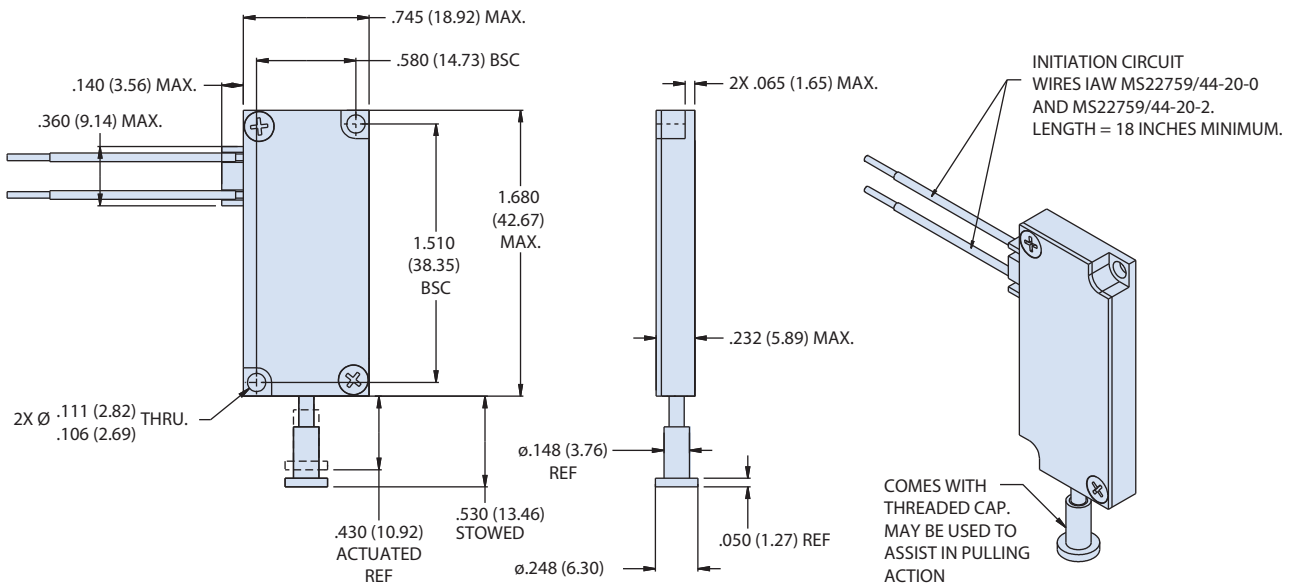

NOTES

- Unit is identified with Glenair name, CAGE code, part number, and date code, space permitting.
- Release preload 12 lbs. (53.3 N)
- Full qualification pending
- Reference Glenair P/N 060-109 for refurbishment initiator
- Metric threads available, consult factory for options
- Unit cannot take any side load

Physical characteristics	
Mass	16.2 grams nominal weight
Material list	IAW MSFC-STD-3029
Epoxy	Outgassing requirements per GSC19384
Device features	
Field refurbishable	Initiator can be replaced in less than 15 minutes by trained personnel
Packaging	External housing typically supplied with two mounting points. Custom housings and mountings available
Scalable bolt size	Bolt size determines preload and can be scaled to accommodate a wide range of requirements
*Size callout based on the bolt size to be used. Metric thread also available. Consult factory for complete test report	