

A

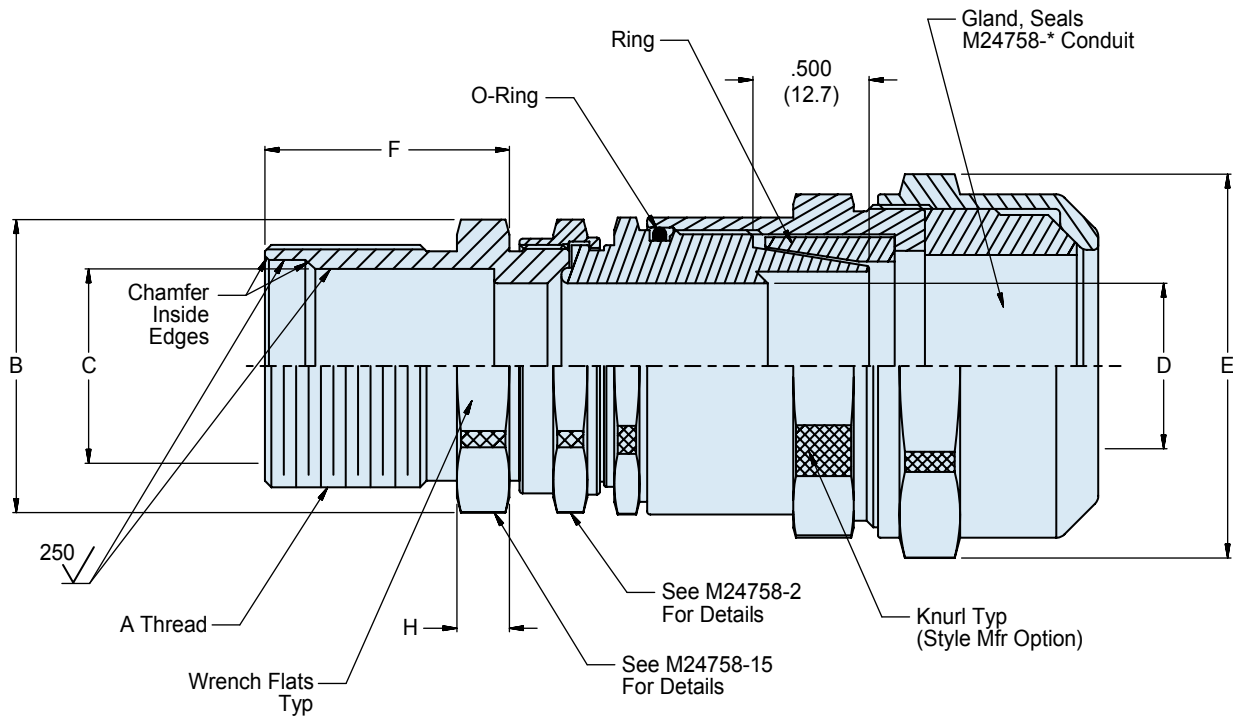
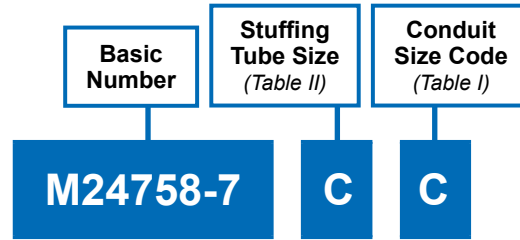

APPLICATION NOTES

1. Assembly identified with manufacturer's code identification number (Glenair, part number and classification code 490).
2. The M24758-7 adapter couples MIL-S-24235/9 through MIL-S-24235/17 stuffing tubes to M24758-* conduit.
3. See M25758-2 for recommended torque values.
4. Material / Finish:
Adapter, nuts, sleeve & ring - 316L SST/Electroless nickel, matte finish.
O-Ring and gland - Silicone rubber / NA.
5. Metric dimensions (mm) are indicated in parentheses.

MIL-PRF-24758-7 Straight Conduit to Stuffing Tube



MIL-PRF
24758A

A

TABLE II

STUFFING TUBE SIZE	CONDUIT SIZE CODE	A CLASS - 2A THREAD	B DIA MAX	C DIA	F ± .020 (0.51)	H ± .020 (0.51)
A	A, B, J	.875-12UN	1.375 (34.93)	.406 (10.31)	1.063 (27.00)	.188 (4.78)
B	B	1.000-12UN	1.500 (38.10)	.515 (13.08)	1.063 (27.00)	.188 (4.78)
C	B, C, K	1.250-12UN	1.625 (41.28)	.640 (16.26)	1.063 (27.00)	.188 (4.78)
D	C, K	1.250-12UN	1.750 (44.45)	.750 (19.05)	1.063 (27.00)	.188 (4.78)
E	D	1.313-12UN	2.750 (69.85)	.812 (20.62)	1.063 (27.00)	.188 (4.78)
F	D	1.625-12UN	2.812 (71.42)	.843 (21.41)	1.188 (30.18)	.188 (4.78)
G	E	1.750-12UN	2.000 (50.80)	.935 (23.75)	1.188 (30.18)	.188 (4.78)
J	E	1.813-12UN	2.125 (53.98)	1.062 (26.97)	1.188 (30.18)	.188 (4.78)
K	E	2.000-12UN	2.250 (57.15)	1.171 (29.74)	1.500 (38.10)	.188 (4.78)
L	E, F	2.063-12UN	2.312 (58.72)	1.265 (32.13)	1.500 (38.10)	.188 (4.78)
M	F	2.188-12UN	2.500 (63.50)	1.406 (35.71)	1.500 (38.10)	.250 (6.35)
N	G	2.313-12UN	2.625 (66.66)	1.515 (38.48)	1.563 (39.70)	.250 (6.35)
P	G	2.688-12UN	2.750 (69.85)	1.625 (41.28)	1.563 (39.70)	.250 (6.35)
R	G	2.875-12UN	2.875 (73.03)	1.750 (44.45)	1.563 (39.70)	.250 (6.35)
S	G	3.000-12UN	3.250 (82.55)	1.875 (47.63)	2.188 (55.58)	.313 (7.95)
T	G	2.875-12UN	3.500 (88.90)	2.062 (52.37)	2.188 (55.58)	.313 (7.95)
V	G, H	3.000-12UN	3.625 (92.08)	2.187 (55.55)	2.188 (55.58)	.313 (7.95)
W	H	3.125-12UN	3.750 (95.25)	2.312 (58.72)	2.188 (55.58)	.313 (7.95)
X	H	3.250-12UN	3.875 (98.43)	2.500 (63.50)	2.188 (55.58)	.313 (7.95)
Y	H	3.375-12UN	4.000 (101.60)	2.609 (66.27)	2.188 (55.58)	.313 (7.95)
Z	H	3.563-12UN	4.250 (107.95)	2.781 (70.64)	2.188 (55.58)	.313 (7.95)
AA	H	3.750-12UN	4.500 (114.30)	2.875 (73.03)	3.125 (79.38)	.438 (11.13)
BB	H, L	4.000-12UN	4.750 (120.65)	3.157 (80.19)	3.125 (79.38)	.438 (11.13)

TABLE I

CONDUIT SIZE CODE	D MIN DIA	E MAX DIA
A	.245 (6.22)	1.140 (28.96)
B	.495 (12.57)	1.460 (37.08)
C	.745 (18.63)	1.780 (45.21)
D	.995 (25.73)	2.030 (51.56)
E	1.245 (31.63)	2.280 (57.91)
F	1.495 (37.97)	2.530 (64.26)
G	1.995 (50.63)	3.140 (79.76)
H	2.495 (63.37)	3.650 (92.71)
J	.370 (9.40)	1.340 (34.04)
K	.620 (15.75)	1.650 (41.91)
L	2.995 (76.03)	4.150 (105.41)

**TABLE III
RECOMMENDED
TORQUE
(See Note 3)**

CONDUIT SIZE CODE	± 5 Inch lbs.	
	A THREAD	SLEEVE
A	40	120
B	45	140
C	50	150
D	80	170
E	80	170
F	80	170
G	80	170
H	80	170
J	45	120
K	50	140
L	80	170