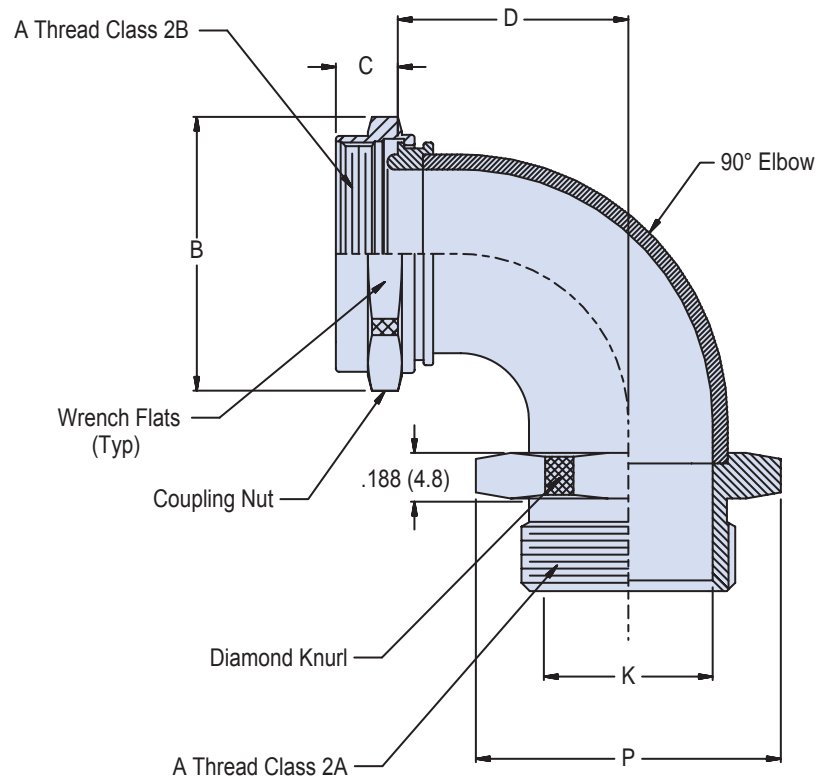

**A**
**Basic  
Number**
**M24758-32**
**Conduit  
Size Code  
(Table I)**
**C**

**APPLICATION NOTES**

1. Assembly identified with manufacturer's code identification number (Glenair, part number and classification code 490).
2. Material / Finish:  
Elbow, coupling nut - 316 SST/Electroless nickel, matte finish.
3. Metric dimensions (mm) are indicated in parentheses.

TABLE I: CONDUIT SIZE CODE

CONDUIT SIZE CODE	A THREAD	B MAX DIA	C +.00 -.03 (0.8)	D ±.06 (1.5) DIM	K MIN DIA	P MAX
A	.438-28 UNEF	.880 (22.4)	.205 (5.2)	.810 (20.6)	.245 (6.2)	.880 (22.4)
B	.688-24 UNEF	1.130 (28.7)	.245 (6.2)	1.120 (28.4)	.495 (12.6)	1.130 (28.7)
C	.938-20 UNEF	1.380 (35.1)	.305 (7.7)	1.470 (37.3)	.745 (18.9)	1.380 (35.1)
D	1.250-18 UNEF	1.690 (42.9)	.365 (9.3)	1.810 (46.0)	.995 (25.3)	1.690 (42.9)
E	1.563-18 UNEF	2.000 (50.8)	.365 (9.3)	2.120 (53.8)	1.245 (31.6)	2.000 (50.8)
F	1.875-16 UN	2.310 (58.7)	.425 (10.8)	2.500 (63.5)	1.495 (38.0)	2.310 (58.7)
G	2.375-16 UN	2.940 (74.7)	.425 (10.8)	3.120 (79.2)	1.995 (50.7)	2.940 (74.7)
H	2.875-16 UN	3.440 (87.4)	.425 (10.8)	3.250 (82.6)	2.495 (63.4)	3.440 (87.4)
J	.563-24 UNEF	.940 (23.9)	.245 (6.2)	.930 (23.6)	.370 (9.4)	.940 (23.9)
K	.813-20 UNEF	1.190 (30.2)	.305 (7.7)	1.250 (31.8)	.620 (15.7)	1.190 (30.2)
L	3.375-16 UN	3.940 (100.1)	.425 (10.8)	4.500 (114.3)	2.995 (76.1)	3.940 (100.1)