

## ITS 31030 GR and ITS 41030 GR Rear Panel Mount Square Flange Receptacle Assembly with Rotating Coupling Nut Backshell for Heat-Shrink Tubing

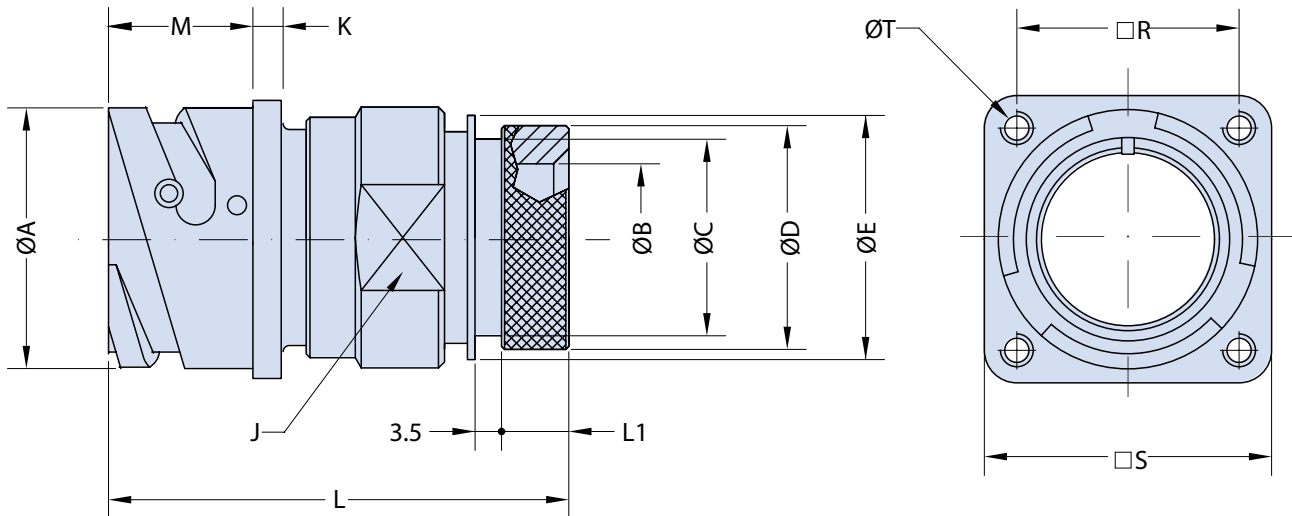
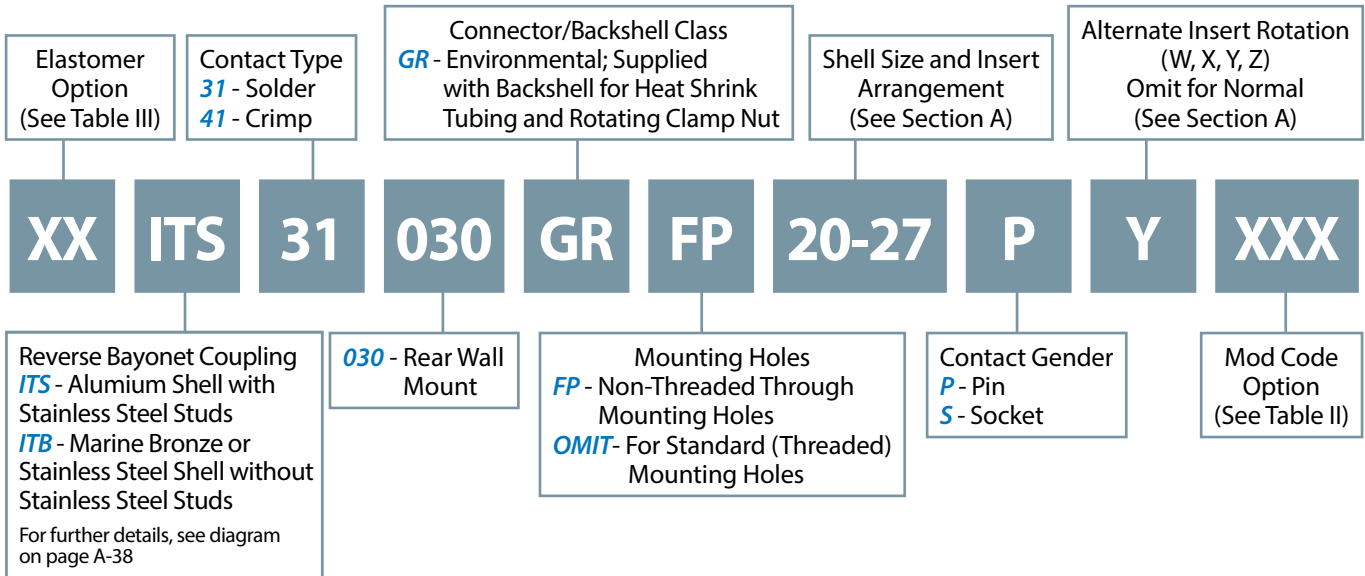

### Application Notes

1. Rear panel mount square flange receptacle with backshell for heat-shrink tubing. Rotating coupling nut supplied. Threaded mounting holes. Optional non-threaded mounting holes available.
2. Environmental class "GR" (environmental)—Wire sealing grommet supplied.
3. Standard materials configuration consists of aluminum alloy. For platings, see TABLE II finish options.
4. Standard contact material consists of copper alloy with silver plating or gold plating.

**ITS 31030 GR and ITS 41030 GR  
Rear Panel Mount Square Flange Receptacle Assembly  
with Rotating Coupling Nut Backshell for Heat-Shrink Tubing**



**TABLE I: DIMENSIONS**

Shell Size	ØA +0.2 -0.1	ØB Min.	ØC ±0.1	ØD ±0.2	ØE ±0.1	J key	K ±0.2	L Max.	L1 ±0.1	M +0.2 -0	R ±0.2	S ±0.2	T Thread
<b>10 SL</b>	18.2	8.6	13.0	15.5	17.0	20	2.8	59.0	8.2	18.4	18.25	25.4	M4
<b>14 S</b>	24.5	10.7	16.5	19.1	20.1	23	3.2	59.0	8.2	18.4	23.00	30.4	M4
<b>16 S</b>	27.2	14.0	24.9	23.9	23.5	26	3.2	59.0	8.0	18.4	24.60	32.5	M4
<b>16</b>	27.2	14.0	24.9	23.9	23.5	26	3.2	64.0	8.0	23.2	24.60	32.5	M4
<b>18</b>	30.7	17.5	21.7	23.9	26.5	28	4.0	66.5	8.0	23.2	27.00	35.0	M4
<b>20</b>	34.0	18.8	26.2	29.6	30.2	32	4.0	67.0	8.9	23.2	29.40	38.0	M4
<b>22</b>	37.3	21.0	26.2	29.6	33.6	36	4.0	67.0	9.2	23.2	31.75	41.0	M4
<b>24</b>	40.9	25.4	34.0	37.8	36.1	39	4.0	70.0	9.5	23.2	34.90	44.5	M4
<b>28</b>	46.7	28.4	34.3	37.8	41.4	46	4.0	70.0	9.2	24.2	39.70	50.9	M5
<b>32</b>	53.4	34.0	43.6	47.8	48.6	52	4.0	72.0	11.7	24.2	44.50	57.0	M5
<b>36</b>	59.6	40.5	43.6	47.8	54.0	58	4.0	72.0	11.5	24.2	49.20	63.5	M5
<b>40</b>	65.5	49.0	52.6	57.8	61.0	65	4.0	72.0	11.5	24.2	55.55	69.9	M5

For through mounting holes refer to page B-3.

**TABLE II: MODIFICATION CODES**

CONTACT OPTIONS		
Sym	Description	
B0	Connector without Contacts**	
B1	Connector with Gold Plated Contacts	
<b>Omit for standard version (Silver plated)</b>		
STANDARD MATERIAL AND FINISH (*)		
Sym	Description	RoHS
	Omit for Aluminum/ Cadmium Olive Drab	
F6	Aluminum/ Black Electrodeposited Paint	✓
F7	Aluminum/ Black Zinc Nickel	✓
F11	Aluminum/ Electroless Nickel	✓
MB	Marine Bronze/ Unplated	✓
FK	Stainless Steel/ Passivate	✓

(\*) For further options, please contact the factory.

(\*\*) Crimp Contacts Only

**TABLE III**

ELASTOMER OPTIONS	
Sym	Description
	Omit for Polychloroprene Elastomer
FR	Fire Resistant Elastomer
S	Silicone Elastomer