

QwikConnect

GLEN AIR ■ JANUARY 2007 ■ VOLUME 11 ■ NUMBER 1

In This Issue:

Glenair's MIL-PRF-24758A Topside Conduit and Adapters are Haze Gray and Underway!





DEPARTMENT OF THE NAVY
NAVAL SEA SYSTEMS COMMAND
1333 ISAAC HULL AVE SE
WASHINGTON NAVY YARD DC 20376

2450
Ser 42/050
18 Nov 06

From: Director, Force Test, Assessment and Readiness
Engineering Division
To: Program Executive Office, Ships (PMS 400D)
ATTN: Mr. J. O'Shaughnessy
1333 Isaac Hull Ave SE, Washington Navy Yard, DC 20376

Subj: APPROVED EMI/EMP CONDUIT SYSTEMS FOR USE ON TOPSIDE
INSTALLATIONS

Ref: (a) SEA 42 Memorandum 2450 Ser 06/021 of 29 Jan 04
(b) SEA 42 Letter 2450 Ser 06/055 of 18 Nov 05

Encl: (1) Consolidated Glenair MIL-PRF-24758A Test Report
QTR M24758 of 25 Apr 06

1. Reference (a) provided SEA 42E technical review of the Glenair, Inc "First System" conduit testing and documentation with regard to its equivalency to the Entresco "Sea-FROG"™ conduit and Termination System. SEA 42E's technical assessment was that the Glenair "First System" product was mechanically and electrically equivalent to the Entresco "Sea-FROG"™ system. Subsequently, in response to the issuance of MIL-PRF-24758A(EM), Glenair developed a MIL-PRF-24758A product line. Test and inspection results were provided in enclosure (1).

2. SEA 42E, the technical warrant holder for EMI Control, EMC, EMP and RADHAR for ships and submarines, has completed a detailed technical review of enclosure (1). Based on this review and the previous review noted in reference (b), it is SEA 42E's assessment that the Glenair MIL-PRF-24758A products tested meet the performance requirements of MIL-PRF-24758A and are considered acceptable to use for EMI/EMP control on topside installations aboard US Navy ships.

3. SEA 06 will provide this information to the Fleet and its support activities via Naval message. This message will also reiterate the policy that only rigid conduit and conduit systems that meet the performance requirements of MIL-PRF-24758A are approved for topside use in new ship construction, new installations, overhauls and modernization.



Subj: APPROVED EMI/EMP CONDUIT SYSTEMS FOR USE ON TOPSIDE
INSTALLATIONS

4. The SEA 06 point of contact is Mr. D. Mark Johnson, SEA 42E, Commercial (202) 781-3140 or DSN 326-3140. His lead engineer for MIL-PRF-24758A is Mr. Neal Stetson, NSWC Dahlgren Code Q504, (540) 533-3470 or DSN 249-3470.

Vance A. Blausky
VANCE A. BLAUSKY

Copy to:
Commander, Space and Naval Warfare Systems Command (SPANAR),
San Diego, CA (w/o Enclosures)
PFO SHIPS, Washington, DC (PMS 400D/J, O&M, R Popp, SHIPS F1/
S. Brown, SHIPS FPC/E, Littig) (w/o Enclosures)
PFO IWS, Washington, DC (INMIC/LT M. Shine) (w/o Enclosures)
PFO CARRIERS, Washington, DC (w/o Enclosures)
PFO LHM, Washington, DC (CHENG/P. Hagan, PMS 491/G. Nunes,
CAPT J. Spitz, E. Haas) (w/o Enclosures)
PFO C4I and SPACE, San Diego, CA (w/o Enclosures)
Commander, NSWC Dahlgren, Dahlgren, VA (Code Q504/W. Stetson,
Code Q54/G. Winters)
Commander, NSWC Dahlgren, Dahlgren, VA (Code Q504/W. Stetson,
Data Base) (w/o Enclosures)
Northrop Grumman Ship Systems, Washington DC (R. Buffler)
Glenair Inc, Glendale CA (D. Holden) (w/o Enclosures)
Porane Manufacturing Inc, Ivyland PA (R. Nagross)
GDIT, Washington DC (M. Craig, A. Church) (w/o Enclosures)
GDIT, Dahlgren VA (R. Ayers) (w/o Enclosures)

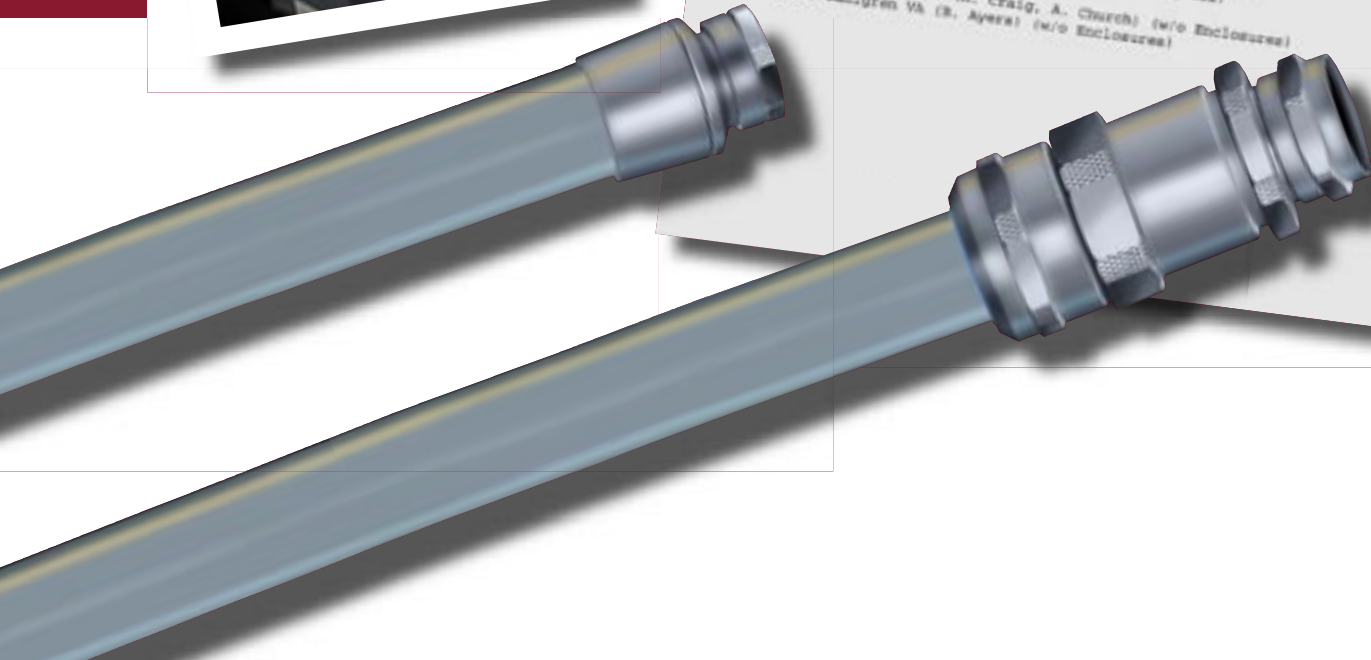

“Only Rigid Conduit and Conduit Systems that Meet the Performance Requirements of MIL-PRF-24758A are Approved for Topside Use...”

—U.S. DEPARTMENT OF THE NAVY

When we set out to design an innovative conduit system to meet the requirements of the new MIL-PRF-24758A(SH) specification, we had a simple goal in mind: create a conduit system which was easy to install, easy to maintain and tough enough to perform in even the harshest ocean environments. The results couldn't be better. Our new qualified MIL-PRF-24758A(SH) Conduit system with its “BlueJacket” weatherproof jacketing exceeds the performance specifications for improved waterproof sealing, improved corrosion protection, and improved electromagnetic shielding. In fact, we believe no other conduit system can match the quality and performance of our new “BlueJacket” system. The U.S. Navy has cast its vote: Glenair’s MIL-PRF-24758A conduit systems are the first products approved by the



Glenair “BlueJacket” is designed to withstand the most arduous sea conditions with uninterrupted environmental and electromagnetic performance. The EMI/EMP shielded conduit system is equally well-suited for other, non-maritime applications that require reliable performance under arduous environmental conditions.

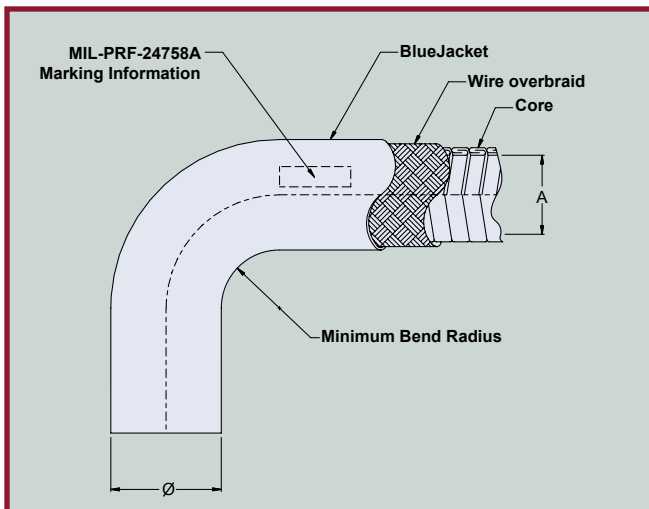

Our jacket material, which we’ve named “BlueJacket” in honor of the dedicated Navy personnel who work with these products, is a special formula that exceeds all the specifications of MIL-PRF-24758A.

Navy under the new specification for topside use in new ship construction, new installations, future repairs, overhauls and modernization.

Glenair’s “BlueJacket” weatherproof conduit is halogen free, flame resistant, and functional to 200°C. “BlueJacket” far surpasses the accelerated solar weathering standards under IEC 60068-2-5. Our new fittings and adapters are equally impressive. The nickel plated 316L stainless steel components are equipped with rotatable couplings to simplify field installation. The design also offers improved environmental sealing, mechanical and electrical performance as well as improved metal-to-metal termination of EMI shielding.

Glenair MIL-PRF-24758A Qualified “BlueJacket” is Haze Gray and Underway!

Shipboard interconnect systems are subjected to harsh environmental challenges. Even in such difficult conditions, the Navy expects interconnected electronics to operate flawlessly—minor failures can result in loss of life and property. It is not surprising, therefore, that Navy installation, maintenance and performance standards are among the most rigid and demanding found in any industry. These standards are designed to protect electronics from extremes in vibration, shock, immersion, temperature, pressure, chemical exposure, as well as electromagnetic and radio frequency interference. In addition to these exposures, modern shipboard standards call for minimization of corrosion and reduction of weight.



“BlueJacket” conduit comes standard in Fed Std 595B gray. The material is also available in a broad range of custom colors—including white.

Glenair is the premier manufacturer of high-reliability shipboard interconnect hardware, with all the key military standard approvals. Our application engineers work directly with military and merchant shipbuilders worldwide to design our highly specialized line of shipboard interconnect hardware. Navy, shipboard and marine interconnect solutions from Glenair’s include:

- The new “BlueJacket” Qualified MIL-PRF-24758A and legacy Qualified MIL-C-24758 Conduit Systems and Fittings
- Cable Shield Grounding Assemblies
- Ex-Barrier Glands
- Sigmaform Backshells
- Data Cable Hummer Adapters
- Mil-C-28840 Qualified Circular Connectors and Accessories
- MIL-PRF-28876 Style Fiber Optic Connectors
- U.S.Navy and U.K. MOD Approved Composite EMI/RFI Junction Boxes

New MIL-PRF-24758A Metal Core Conduit and Fittings

As mentioned above, Glenair is proud to announce its qualification to the new MIL-PRF-24758A Conduit and Fitting Specification. Glenair’s “BlueJacket” conduit systems are now approved by the Navy for all topside use in new ship construction, new installations, overhauls and modernization, and Glenair is currently a qualified provider.

The MIL-PRF-24758A(SH) performance specification calls for improved waterproof sealing and improved corrosion protection. Glenair’s “BlueJacket” design combines the best high temperature conduit with new backshell style sealing features. Using a new proprietary formula, Glenair’s “BlueJacket” weatherproof conduit is halogen free, flame resistant, and functional to 200°C. “BlueJacket” far surpasses the accelerated solar weathering standards under IEC 60068-2-5—the standard calls for 10 accelerated days (equal to approximately 10 years) of solar exposure. Glenair “BlueJacket” tested to 56 accelerated days, equivalent to 53 years of solar exposure. “BlueJacket” also meets the low smoke index per NES 711 (11.75), and the toxicity index per NES 713 (1.9). Further, “BlueJacket” conduit protects wiring from fuel, hydraulic fluid, lube oil, cleaners, solvents,

de-icers, coolants, refrigerants, and fire extinguisher foams. Gray color (Fed Std 595B 26270) matches standard U.S. Navy hull color for easy deployment and reduced maintenance.

“BlueJacket” installation is easy—new fittings eliminate termination compression leaks as braids terminate with metal-to-metal contact and jacketing with rubber-to-rubber contact. Another major enhancement to termination fittings is the addition of rotatable couplings to simplify field installations. Glenair is also able to offer a complete range of factory-terminated conduit assemblies with lightweight solder fittings qualified to MIL-PRF-24758A. Both styles mate to all legacy MIL-C-24758 adapters and connectors.

Glenair “BlueJacket” conduit and fittings are perfectly suited for topside applications, including shipboard weapons, communications, and radar. “BlueJacket” is also suited for use in areas exposed

to the extreme heat of gas turbine exhaust. The product is equally appropriate for use in non-maritime applications that require durable and reliable performance.



Glenair “BlueJacket” flexible EMI/EMP conduit is U.S. Navy approved for new ship construction, repairs and overhauls.

Glenair “BlueJacket” Material Specifications

Temperature rating: -70°C to +200°C (with excursions to 260°C)

Halogen free per IEC 60614-1. Less than 5mg of HCL per 1 gram of product tested.

Accelerated Weathering (Solar) per IEC 60068-2-5; 56 days exposure

Flame Resistant per IEC 60614-1; Material does not sustain combustion when the source of flame is removed.

Low Smoke Index per NES 711 (11.75); Minimum standard is 25. The Glenair tested level is 11.75. This makes the material acceptable for interior applications as well as topside use.

Smoke Density Class F1 Per NF F 16-101 IAW DIN EN 60695-2-11:2001

Toxicity Index per NES 713 (1.9); Minimum standard is 5. The Glenair tested level is 1.9. This makes the material acceptable for interior applications as well as topside use.

Colorable to Fed Std 595B

Markable IAW MIL-PRF-24758A

Oxygen Limiting Index = 45.1 Per EN ISO 4589-2:1999; Minimum is 28.

12 Sec Vertical Burn: (Pass) Per 14CFR Part 25.853(a) AMDT 25-116 App F Part 1 (a)(1)(ii)

Fluids Per MIL STD 810F, Method 504

Fuel (MIL-T-83133): JPG

Hydraulic Fluid (MIL-H-5606): ROYCO 756

Lube Oil (MIL-L-23699): ROYCO-500

Cleaner (MIL-C-85570): CALLA-855

Solvent (Isopropyl Alcohol): TT-I-735

De Icer (AMS-1432): E36 Runway Deicer

Coolant (MIL-C-87252): Coolanol 25R

Fire Extinguishant Foam: AMEREX AFFF

Glenair MIL-PRF-24758A “BlueJacket” Conduit Component Selection Guide

This section of *QwikConnect* is designed to assist with the selection of components and planning for installation of MIL-PRF-24758A(SH) conduit and fittings. Per current U.S. Navy policy, only MIL-PRF-24758A qualified systems are now approved for topside use. To cross over part numbers from other manufacturers or the original MIL-C-24758 specification, please contact the factory at (818) 247-6000.

Each point-to-point conduit assembly will require a length of bulk conduit, 2 conduit fittings (M24758-2, -3, or -4) and 2 adapters (M24758-9 through M24758-24). You have three basic options for putting all these parts together:

- (1) Specify user installable components (bulk lengths of conduit, fittings and adapters designed for field assembly),
- (2) Select made-to-order conduit assemblies built at the factory according to your exact size, length and routing requirements, or
- (3) Use a combination approach in which one

end of the conduit is terminated at the factory with lightweight solder fittings, while the other end is terminated in the field with user installable fittings and adapters.

Step 1: Select Correct Conduit Size

Conduit size is identified by its inside diameter (ID). The ID is referenced with a size code. The range of available sizes includes .25 inch (M24758-A) through 3.0 inch (M24758-L).

Conduit is normally filled at up to 90% of its inside diameter. Verify the cable diameter used before selecting the conduit diameter. Low smoke shipboard cable (MIL-C-24643) may have a thicker jacket material than regular (MIL-C-915 and MIL-C-24640) cables and require larger diameter conduit and fittings, so be sure to take this into account.

The shipboard interface, i.e. the diameter of the stuffing tube on the ship the conduit assembly will attach to, is the other key data point for conduit size selection. In a well-designed system, the

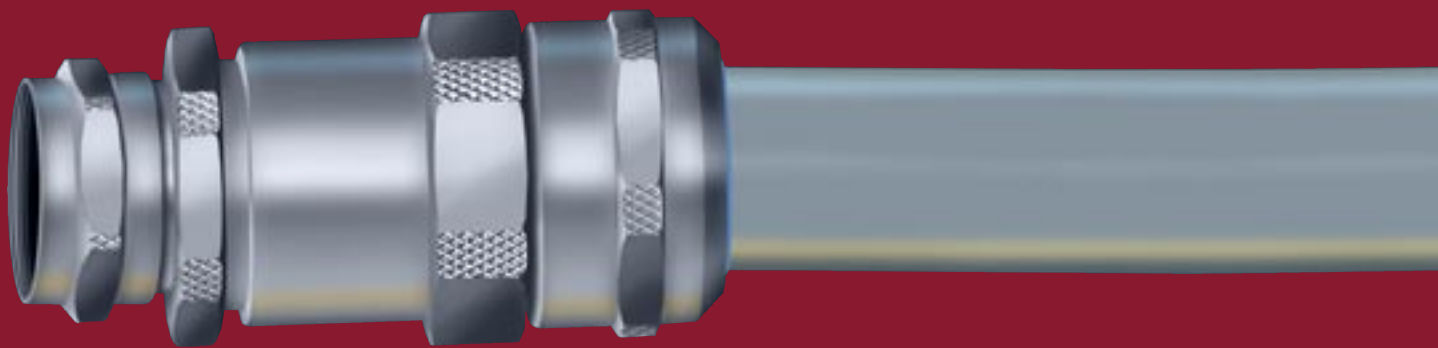

Stainless steel M24758 fittings for field termination and assembly are supplied in straight, 45° and 90° designs. Glenair MIL-PRF-24758A qualified fittings feature unique metal-to-metal shield termination, robust environmental sealing, and a rotatable coupling for easy attachment of M24758 series adapters. Both the environmental sealing and EMI shielding functions incorporate design ideas adapted from military standard backshells, including environmental o-rings, cable-sealing glands and cone-and-ring style shield terminations.

diameter of the conduit, fitting, adapter and stuffing tube all need to be the same. For example, a size code "D" (1 inch) conduit would be selected when the stuffing tube on the ship is also 1 inch in diameter.

NOTE 1: The color of Mil-PRF-24758A conduit is standard US Navy haze gray in accordance with Fed Std 595B #26270. If other colors are desired, contact the factory at (818) 247-6000.

NOTE 2: Conduit internal dimensions 3/8", 5/8", and 3" have been omitted from the MIL-PRF-24758A specification. Products using these dimensions, built to the same standards, are still available from Glenair.

NOTE 3: The operating temperature variant of the M24758A jacket material used on the conduit is -70°C to + 200°C. For higher temperature materials, contact the factory.

Step 2: Select Conduit Fittings

The function of the M24758 conduit fitting is to terminate M24758 flexible shielding conduit and to provide a standard thread for attaching M24758-9 through M24758-24 adapters. Fittings are supplied in straight, 45° and 90° configurations to facilitate the routing of the conduit into and out of kick-pipes and

other interfaces to the ship. Selection is a simple matter of matching the size code in the part number with the size code of the selected conduit. Your selection of a straight, 45° or 90° angled part will depend on the routing requirements of your system.

NOTE 1: All conduit fittings and adapters feature a combination of hex wrench flats and knurls to minimize the need for special installation tools.

NOTE 2: Glenair recommends the use of torque wrenches to ensure conduit fittings and adapters are mated with the optimal amount of torque. Torque wrenches required for installation are available from Glenair. Please see the Glenair Tool Catalog for order information.

All conduit fittings and adapters are matte finished, nickel plated, 316L stainless steel. If other materials are desired, contact the factory.

Step 3: Select Appropriate Adapters

As noted, the conduit fittings selected in step 2 provide a standard thread for the attachment of various adapters. The adapters are used to mate the conduit assembly to the many interfaces found on the ship, such as stuffing tubes or kick-pipes with tapered NPT threads. Adapters are also available to facilitate mating of the conduit assembly to various military standard cylindrical

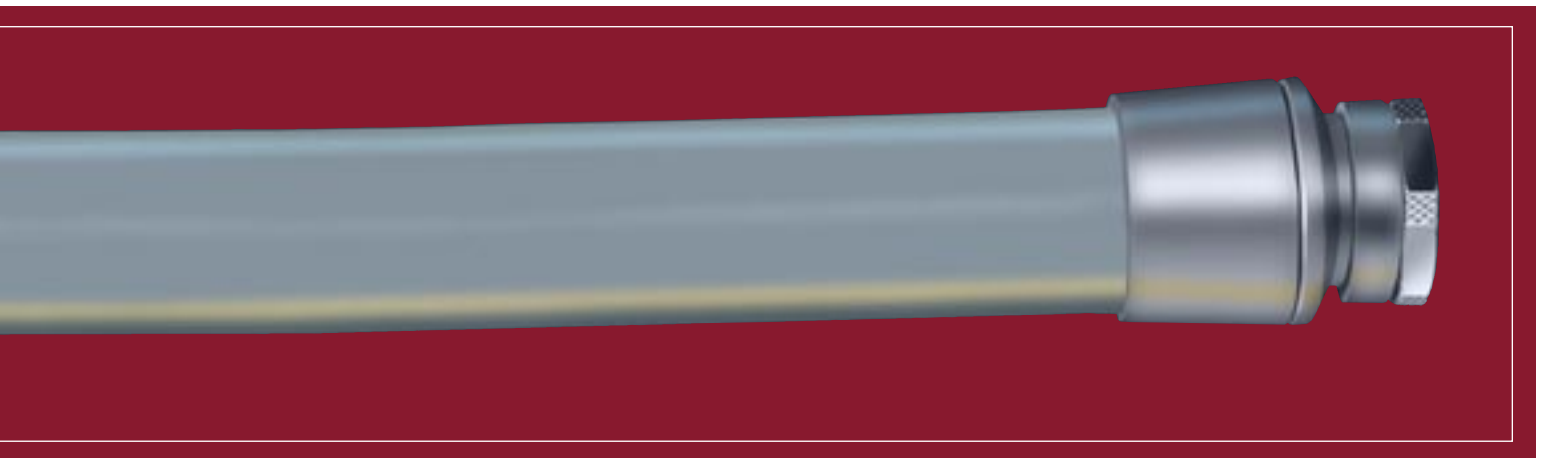

Flexible bulk conduit is supplied with a brass metal core, phosphorus bronze metal overbraiding and Glenair "BlueJacket" outer jacketing material which has been optimized for shipboard and other harsh application environments.

Factory terminated conduit fittings provide the ultimate flexibility in system specification. The lightweight solder fittings mate to all M24758 adapters and offer a maintenance-free alternative to user installed fittings.

connectors. The following are a selection of the standard adapters covered by MIL-PRF-24758A and supplied by Glenair:

- 1. Stuffing tube adapter (AKA swage tube or kick pipe adapter):** These adapters are identified by the stuffing tube size and conduit diameter. See the M24758-15 drawing.
 - 2. Panel adapter (AKA junction box adapter or interconnecting box adapter):** These adapters are identified by the conduit size. The required mounting hole size is shown on the M24758-19 drawing.
 - 3. NPT adapter (AKA tapered pipe thread adapter):** These adapters are identified by the NPT thread size and conduit size. See the M24758-17 drawing.
 - 4. NPSM adapter (AKA National Pipe Thread Standard adapter):** These adapters are identified by the NPSM thread and conduit size. See the M24758-18 drawing.
 - 5. Splice (AKA conduit union adapter):** These adapters are used, in conjunction with M24758-2 fittings, to join two sections of conduit together. See the M24758-23 drawing.
 - 6. MS3100 Series MIL-C-5015 Connector adapter:** These adapters are used with the obsolete MS3100 series solder style connectors. See the M24758-9 drawing.
- NOTE 1:** Do not use the M24758-9 series adapters for MS3400 and MS3450 crimp contact connectors. See item 10 below.
- NOTE 2:** Glenair recommends replacing MS3100 series connectors (and M24758-19 adapters) with the MS3400 series connectors and M24758-13 series adapters.
- 7. Triaxial connector adapter:** These adapters connect the conduit fitting to triaxial connectors. Contact the factory for the order information.
 - 8. Coaxial connector adapter:** These adapters connect the conduit fitting to coaxial RF connectors. See the M24758-11 drawing.
 - 9. MIL-C-26482 connector adapter:** These adapters connect the conduit fitting to the obsolete MIL-C-26482, series 1 connectors. See the M24758-12 drawing.

NOTE 1: Glenair recommends replacing MS312X series connectors (and M24758-12 adapters) with the MIL-C-26482 series 2, MS347X connectors (and M24758-13 series adapters).

- 10. MIL-C-5015, MIL-C-26482, MIL-C-81703 and MIL-C-83723 series crimp contact connector adapter:** These adapters connect the conduit fitting to MS3400, MS3450 and other MIL-C-5015 crimp style connectors, and MS347X, MIL-C-26482 series connectors. See the M24758-13 drawing.
- 11. MIL-C-28840 connector adapter:** These adapters connect the conduit fitting to MIL-C-28840 series connectors. See the M24758-14 drawing.
- 12. MIL-D-38999 series connector adapters:** These adapters connect the conduit fitting to MS 27XXX, series 1 and 2, and D38999 series III and IV connectors. See the M24758-20 drawing.
- 13. MIL-C-22992 series connector adapters:** These adapters connect the conduit fitting to M1734X connectors. See the M24758-21 drawing. Contact factory for MIL-C-22992 Class L connector adapters.
- 14. Glenair Series 22 adapter:** These adapters connect the conduit fitting to Glenair Series 22 connectors. See the M24758-22 drawing.
- 15. Multiple shield termination adapters:** These adapters provide a shield termination mechanism for individual wire shields. See the M24758-24 drawing.

BLUEJACKET

A Seaman in the United States Navy, and the brand name of the Glenair MIL-24758A(SH) Weatherproof EMI Shielded Flexible Conduit System. Although haze gray in color, the product is named "*BlueJacket*" in honor of the dedicated Navy personnel who work with these products under arduous topside conditions.

GEEDUNK

To most sailors the word geedunk means ice cream, candy, potato chips and other assorted snacks, or the place where they can be purchased. In the 1920's a comic strip character named Harold Teen and his friends spent a great amount of time at Pop's candy store. The store's owner called it The Geedunk (for reasons never explained).

Glenair MIL-PRF-24758A(SH) Qualified Conduit-to-Conduit Fitting Termination Instructions

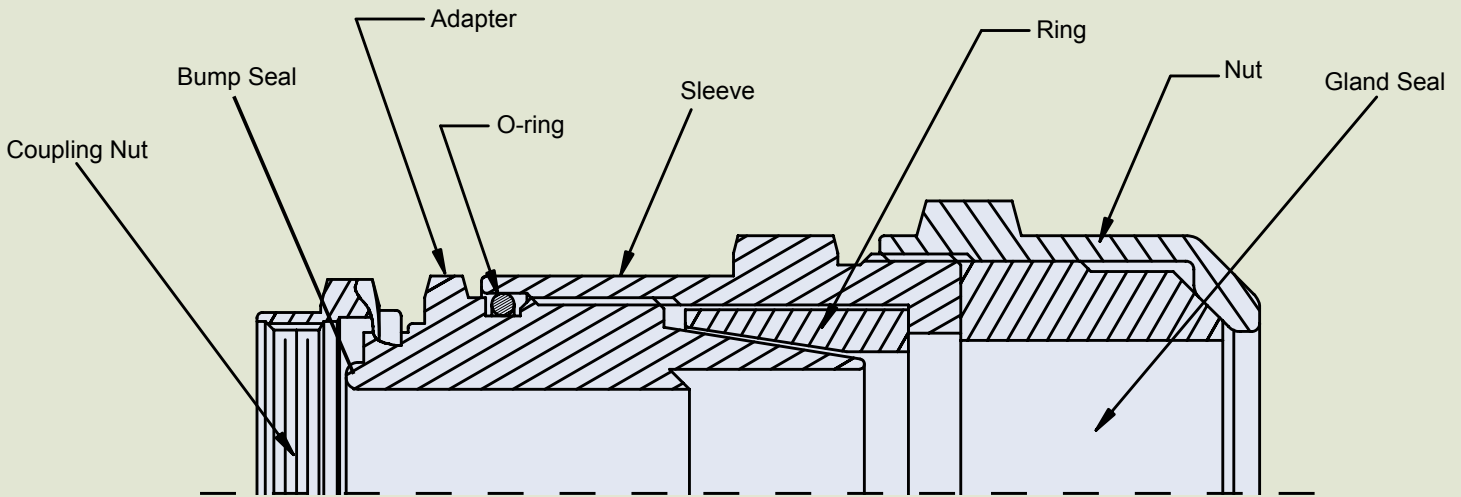

Tools:

Tin snips or scissors capable of trimming conduit and braid
Hacksaw or chop saw
Anti Seize Compound such as NSN 8030-01 450 4009 Tef Gel
Razorblade
Adjustable wrench (Rigid E110 or similar)
Silicone O-ring lube
Vice or second wrench
Needle-nose pliers

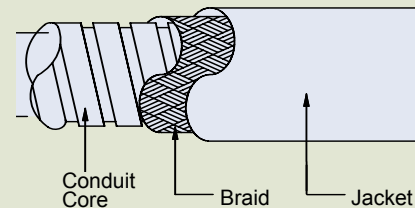

Preassembly instructions: Disassemble fitting and ensure all thread engagements are smooth and burr free. Lubricate cable-sealing gland and O-ring with silicone lube.

1. Measure conduit to desired length (better long than short) and cut to length.
2. Using snips, trim end of conduit, braid and jacket. Ensure all bent edges are removed or smoothed.
3. Slide sleeve, nut and gland seal up conduit (out of way).
4. Using ring as a guide, cut jacket back 1/4" (6.35mm) wider than ring.
5. Slide ring over braid to edge of jacket.
6. Insert cone portion of adapter under braid and ring over conduit core. Apply anti seize to threads.
7. Slide sleeve down conduit and engage threads on adapter. Tighten sleeve until it bottoms out against adapter. O-ring should not be visible.
8. Slide gland seal and nut down to engage thread on sleeve. Tighten until only a small portion of blue gland 1/32" (.793mm) seal is visible above nut.

Legacy MIL-C-24758 Waterproof Flexible EMI/EMP Conduit Systems and Fittings Still Available

Glenair continues to offer cable and wire protection solutions for shipboard applications that call for qualified MIL-C-24758 conduit products. The MIL-C-24758 series is compatible with virtually every type of electrical connector and interconnect system, and can be supplied completely wired and terminated—ready for use—or as component elements. A complete range of fittings, transitions, adapters, shielding, overbraiding, and jacketing satisfies the most complex and demanding applications—from test equipment, robotics, and missile launch systems to shipboard warning systems and naval avionics.

For superior shielding performance and crush resistance, Glenair standard M24758/1 conduit offers a brass inner core with a bronze overbraid, sealed from the weather by a neoprene outer jacket. The brass conduit may also be ordered with a compressed inner core for increased flexibility. For applications where crush resistance is not required, Glenair offers a fluorocarbon (FEP) inner core with two, tin-over-copper braids and a neoprene outer jacket.

Glenair's complete range of conduit, tubing and fittings have been tested and approved to all applicable Mil-Spec standards and provide optimal EMI, EMP, and RFI shielding across all frequencies including H and E fields, TEMPEST and lightning strike. Glenair's MIL-C-24758 conduit systems also provide protection from nuclear fallout, biological and chemical (NBC) attacks. The rugged materials offers outstanding abrasion-protection, flexibility, and temperature protection. Conduit systems can be assembled and repaired in the field or at our factory. A qualified supplier of NAVSEA RP2000 and GR2000 series fittings, Glenair continues to design and manufacture many additional MIL-C-24758 style products to meet specific customer and industry needs for a wide range of applications.

Glenair's stocks MIL-C-24758 bulk conduit for rapid response to your requirements. Most fittings, adapters and accessories are in our Same Day inventory ready for immediate shipment.

Cable Shield Grounding Assemblies

Our line of Cable Shield Grounding Assemblies are available in male, female and split versions and provide reliable 360° grounding of shielded cables to above deck stuffing and swage tubes. Designed to insure both reliable EMI/EMP shielding as well as strict environmental protection, Glenair's Cable Shield Grounding Assemblies also meet MIL-STD-1310 grounding requirements and NAVSEA 803-5001-27 sealing requirements. Cable Shield Grounding Assemblies are available in 18 sizes to accommodate stuffing tube sizes A through V. Supplied in kit form, each Cable Shield Grounding Assembly includes the complete grounding assembly as well as an adhesive-coated heat shrinkable sleeve and Permatex 133A anti-seize compound.

Cable Shield Grounding Assemblies ease cable repairs and replacements while maintaining EMI shielding and water-tight ship integrity. The split version Cable Shield Grounding Assembly allows cable repair without full re-wiring. Glenair has Cable Shield Grounding Assemblies in stock, ready for Same Day shipment.

Glenair Sigmaform Backshells

Glenair Sigmaform backshells provide environmental sealing, strain relief, shield termination and decoupling prevention in convenient one-piece solutions. Available in stainless steel or aluminum, each of three designs incorporates an integrated shrink boot, ready for easy installation and final recovery over the backshell body. Choose from a wide range of adapter angles, including 30°, 45°, 60°, and 90° configurations. Standard spin coupling

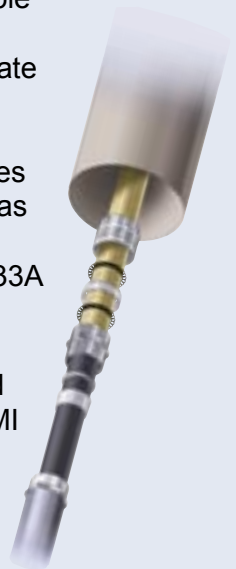
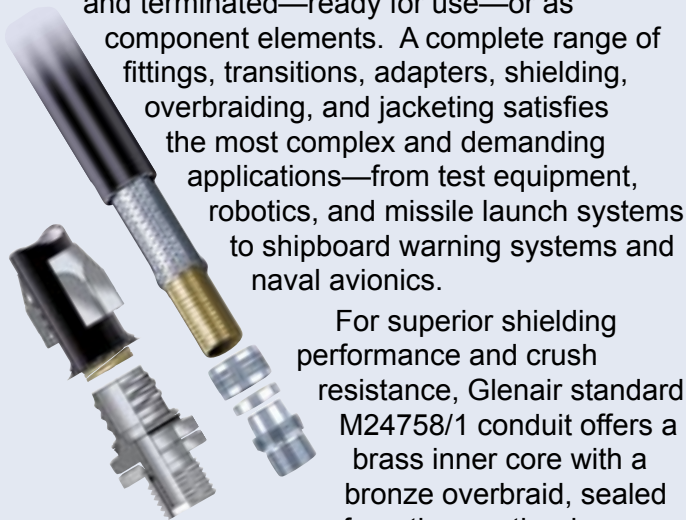

nuts and self-locking nuts are also available as are special low profile 90° models.

Moistureproof Data Cable Hummer Adapters

The Glenair Data Cable Hummer Adapter provides environmental protection, EMI shield grounding and strain relief for shielded data cables penetrating exposed control and junction boxes. The Hummer is typically used on weather decks, up masts, in fire control systems or in other harsh environment applications to prevent



rain, salt spray, corrosive fluids and electromagnetic interference from damaging

critical wiring and control box terminations. A unique candelabra thread end-fitting terminates cable shielding and convoluted tubing. Each Hummer is supplied with an adhesive shrink boot for combined environmental protection and cable strain relief.

Glenair Hummer Adapters are available in brass, aluminum, stainless steel and composite thermoplastic with optional plating choices. Composite versions of the Glenair Hummer are ideally suited for use with Glenair *CostSaver* Composite Junction Boxes to create an extremely light weight and corrosion-resistant cable junction solution.

Qualified MIL-C-28840 Circular Connectors and Accessories

MIL-C-28840 connectors are designed for severe environments, primarily for shipboard applications for both above and below deck. Applications include missile fire control systems, power supplies, guidance systems, radar, cable runs, ship to shore cable assemblies, and land based shelters.

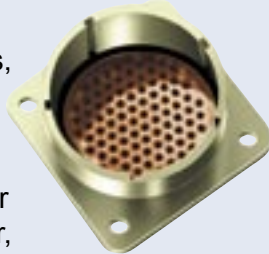

Glenair's is your one-stop choice for qualified MIL-C-28840 connectors, backshells, adapters and accessories, with comprehensive slash sheet



coverage. The standard for shipboard use, MIL-C-28840 connectors offer high density, scoop proof insert arrangements with front-release crimp contacts that accommodate 3 wire sizes (20, 26 and 28 AWG), ideal for use with Navy MIL-C-915 shipboard cable and MIL-W-16978 wire. Conferring excellent environmental and EMI resistance, MIL-C-28840 connectors provide high-shock performance in plugs and flange mount, jam-nut, and in-line receptacles with keyed, threaded-coupling. Choose from nine shell sizes, 11 to 33, with 7 to 155 contacts. These rugged connectors are optimized for resistance to fluids, corrosion, high shock and sustained vibration, while providing excellent EMI/RFI protection. Additionally, the connectors have shell to shell grounding prior to any electrical contact engagement.

Straight, 45° and 90° connector and adapter assemblies are also available. Best of all, many MIL-C-28840 connector, accessory and connector saver part numbers are available for immediate shipment from our extensive Same-Day Inventory.

MIL-PRF-28876 Style Fiber Optic Connectors

MIL-PRF-28876 interconnection systems have become the universal standard for Navy shipboard fiber optic applications and Glenair's offering delivers all the necessary performance—precise optical alignment, environmental protection, and corrosion resistance for shipboard environments. The Glenair MIL-PRF-28876 style interconnect is available in multiple plating and backshell options, including some varieties not currently included in the MIL-PRF specification. MIL-PRF-28876 type connectors are available in plug and receptacle styles in multiple shell sizes and insert arrangements including 2, 4, 6, 8, 18, and 31 channel configurations, with singlemode and multimode capability. The MIL-PRF-28876 style connector is highly resistant to corrosion, environmentally sealed, very durable, and designed to meet severe shock requirements. This interconnection system uses MIL-PRF-29504/14 and /15 style termini, also available from Glenair.

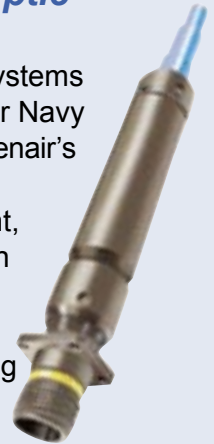

Advanced Corrosion Control for U.S. Navy Surface Ships—Freighters, Gators and Shooters

Metal junction boxes are a maintenance nightmare. Between salt spray, sun, fuel exhaust and rain, most above-deck junction boxes are ready for replacement before they've seen even two years of service. Despite the most aggressive maintenance program, metal boxes will corrode to pieces under the harsh environmental conditions of a ship at sea.

Glenair's corrosion-free composite junction boxes are different. NAVSEA approved for use in U.S. Navy surface ships, (NAVSEA Drawing No. 803-6983056)

Glenair composite electrical boxes can withstand years of harsh environmental abuse without degradation from rust, corrosion, or maintenance cycles. The boxes are resistant to EMI, corrosive fluids, exhaust gasses, high temperatures, shock and vibration and other harsh environment stress factors.

OPEVALs on CVN/DDG/LHD/CG class ships have proved these boxes extend ship service life and reduce costs. NAVSEA estimates wholesale adoption of the boxes throughout the fleet would produce \$64.5M of labor and material cost savings.

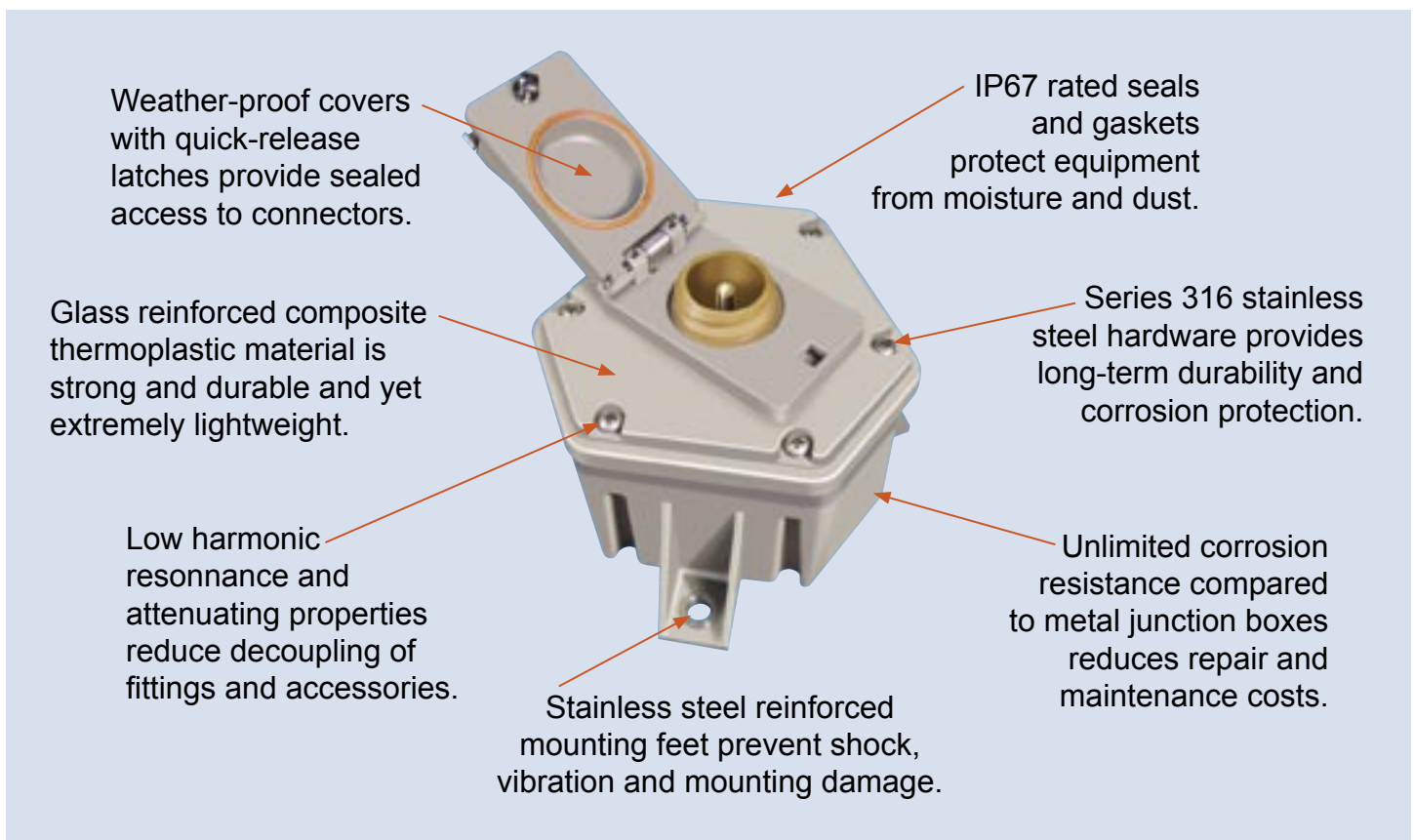

Tested and Approved Materials, Designs and Applications

Glenair Composite Boxes are made from polyetherimide (PEI), a 30% glass-fiber filled amorphous thermoplastic. Polyetherimide offers outstanding high heat resistance, high strength and broad chemical resistance. The material is inherently flame resistant with low smoke emission and zero halogen outgassing. PEI is radiation-resistant, microwave transparent, naturally flame-retardant, and may be plated for EMI resistance and grounding, making it an ideal replacement for aluminum, brass, steel and other metals.

Glenair Standard US Navy Composite Boxes	
Stock Code	Box Descriptions
CDNWC 655-03-001 (NAVSEA umbrella stock code for the Glenair Electrical Junction Box Series).	Junction Box, with or without terminal blocks, four sizes
	Electrical Box, 115V, 15 Amp, two sizes, single and dual receptacle
	Sound Powered Telephone Box with Glenair composite jack receptacle; single, dual and quad.

Series 140-060 Junction Box for is designed for use with standard jacketed cable and M24758 conduit fittings—all NAVSEA approved and available from Glenair.



Series 140-060 Junction Boxes may be supplied by Glenair equipped with indicator lights, switches, controls and other modifications.



Series 140-020 dual gang electrical box provides corrosion-free electrical access in both below deck and topside applications.

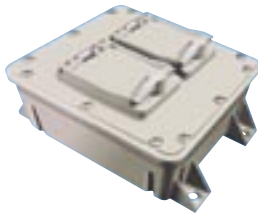

Lids and Covers: Two styles of environmental flop lids protect electrical outlets in shipboard and severe weather deck applications.

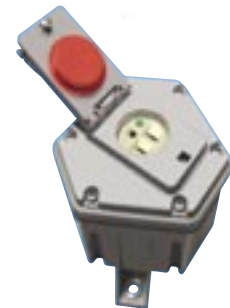

NAVSEA Composite Box Performance Requirements		
Test	Issue	Requirement
MIL-S-901	Shock	Grade A, Class A, No Failure
MIL-STD-167-1	Vibration	2-Hour Test, No Failure
MIL-STD-1344	Impact/Random Drop	Six Times, 4 ft Drop, No Failure
MIL-STD461/1310	EMI/EMP	2 Frequency Ranges
MIL-STD-810	Salt Fog	96 Hour Wet/Dry, No Corrosion
MIL-STD-810	High and Low Temperature	-28 F to 149 F, 3 Days, Function, No Cracking
MIL-STD-108	Spash Proof, Watertight	Hose Spray, 5gpm., No Liquid Penetration
MIL-STD-810	Solar Radiation	56, 24 Hour Cycles, No Color Change
ASTM E 162	Flame Spread/Dripping	25, Self Extinguish, No Drip
ASTM E 1354	Smoke/Heat Release	Cone 25, 50, 75 kW/m2
ASTM E 662	Smoke Density	Smoke < 200
NAVSEA	Fire Containment	2.5 KW for 3.5 Minutes

Basic Box Envelope			
Part Number	Length	Width	Height
Small: 140-060-01	6.0	5.2	3.4
Medium: 140-060-01	6.8	5.9	4.3
Large: 140-060-02	9.0	9.0	4.5
Round: 140-060-05	4.8	4.8	2.9
Dimensions in inches, consult factory for details			

Color and Finish: All box exteriors are unplated and colored to standard U.S. Navy Ship Gray (Glenair XO finish). An optional XMS finish is available for EMI applications which adds electroless nickel plating to all interior box surfaces. Please consult our factory or NAVSEA for additional details.

The NAVSEA family of corrosion-free composite boxes (NAVSEA Stock Code CDNWC 655-03-001) currently includes four different functional styles: A versatile junction box equipped with an internal mounting plate; a terminal box which incorporates NAVSEA-specified terminal blocks; an electrical box in single- and dual-outlet configurations; and a sound-powered phone box with single, dual or quad hook-ups. All boxes are made from corrosion-free composite thermoplastic and are equipped with CRES 316 hardware and o-ring sealed tongue and groove lids. Stainless reinforced standoffs provide trouble-free mounting.

Junction Box Series (Glenair Series 140-060)

Designed for use in harsh environmental (weatherdeck, up-mast) applications which require EMI/RFI protection for data transmission cables. Junction boxes are available in four different sizes and are conductively plated (internally) for EMC. A mounting plate is pre-installed for convenient attachment of terminal blocks, indicator lights and other electrical/electronic hardware.



Terminal Box Series (Glenair Series 140-060T)

These internally plated composite junction boxes are available in four sizes—small round, and small, medium and large rectangular. They are pre-equipped with terminal blocks for convenient installation and routing of electrical media.

Sound Powered Phone Series (Glenair Series 147-021 and 022)

This specialized series of composite boxes is ready for turnkey application servicing single, dual and quad sound powered phone hookups. Custom designed flop-lids seal tight when not in use to prevent water ingress. The boxes, which do not require EMI protection, are shipped unplated.

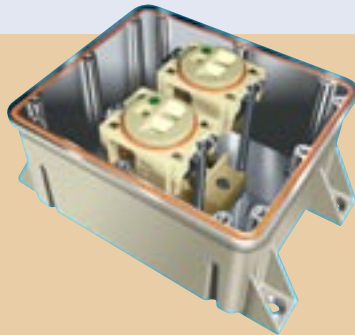
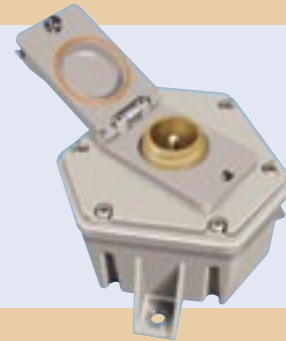

Electrical Box Series (Glenair Series 147-020, 023, 032, and 033)

This box series distributes electrical power outlets where and when they are needed in both harsh, weatherdeck applications and general-purpose shipboard applications. The corrosion-free boxes are available in single and dual outlet configurations. Internal plating facilitates grounding and prevents the generation of EMI. Custom designed flop-lids seal tight when not in use.

How to Order

Box/Part Type	Glenair Series Part Number	Navy Symbol Number
Junction Boxes		
Small Round	140-060XMS-05	-
Small Rectangular	140-060XMS-01	-
Medium Rectangular	140-060XMS-02	-
Large Rectangular	140-060XMS-03	-
Electrical Boxes		
Small Round Box, Single Gang, 115V, Flop Lid	147-023XMS-01	735.3
Small Round Box, Single Gang, 115V, Collar Mate, Flop Lid	147-023XMS-02	1099.1
Small Round Box, Single Gang, MS3402 Connector, Flop Lid	147-033XMS-0003	1098.1
Small Round Box, Single Gang, 125V, 400Hz, Threaded Cap	147-032XMS-0005G	1101
Small Rectangular Box, Dual Gang, 115V, Flop Lid	147-020XMS-02	-
Medium Rectangular Box, Dual Gang, 115V, Collar Mate	147-020XMS-05	-
Sound Powered Phone Box		
Small Round Box, Single Gang, Flop Lid	147-022XO-01	2841
Small Rectangular Box, Dual Gang, Flop Lids	147-021XO-02	2842
Medium Low Profile Box, Quad, Flop Lids	147-021XO-03	2843
Terminal Boxes		
Small Round	140-060XMS-05T2	5201
Small Round	140-060XMS-05T4	400
Small Rectangular	140-060XMS-01T3	435.1
Small Rectangular	140-060XMS-01T4	528
Small Rectangular	140-060XMS-01T6	444
Large Rectangular	140-060XMS-03T1	432.1
Large Rectangular	140-060XMS-03T2	434
Large Rectangular	140-060XMS-03T5	529
Large Rectangular	140-060XMS-03T9	433.1
Large Rectangular	140-060XMS-03T10	522.1
Large Rectangular	140-060XMS-03T11	446
Large Rectangular	140-060XMS-03T12	525
Replacement Parts and Fittings		
Composite Feedthrough Adapter*	637B094XB02102CB	-
Composite Sound-Power Receptacle Connector	227-059XO04W	-
Replacement Sound-Power Flop Lid Cover Assembly	630-038XO-02K	-
Replacement Electrical Flop Lid Cover Assembly	630-038XO-01K	-
Replacement Collar Mate Flop Lid Assembly	630-038XO-04K	-
Replacement Cover Screwkit	687-499-1	-
Turnkey Box/Panel Assemblies		
LSD41 Class Ship Stern Gate Control Panel Assembly	149-003	-
LSD49 Class Ship Stern Gate Control Panel Assembly	149-004	-
CVN Nimitz Class Elevator Control Communication System	147-038XMS-002	-

* Universal composite feedthrough fitting includes sizing grommets for various cable sizes

NAVSEA Approval: Glenair advanced, corrosion-control composite electrical boxes are now NAVSEA approved for deployment around the fleet. The top-level NAVSEA drawing covering these composite electrical enclosures is No. 803-6983056. All testing has been completed and NAVSEA is working with NAVSUP Mechanicsburg to introduce the individual boxes and replacement parts to the stock system. For NAVSEA contact information or for the latest procurement information on these CDNWC 655-03-001 NAVSEA Stock Code products please contact Glenair, Inc. at (818) 247-6000.

New projects: Glenair is also working closely with NAVSEA on the ongoing development of additional panel installations and new box configurations including an LED deck lighting system built around the Glenair composite box design.

Glenair salutes and extends its thanks to the many officers and sailors who participated in sea trails to evaluate and perfect the NAVSEA composite box conversion project, including the men and women of the following ships:

- USS George Washington (CVN-73)
- USS Theodore Roosevelt (CVN-71)
- USS Barry (DDG-52)
- USS Comstock (LSD-45)
- USS Vella Gulf (CG-72)
- USS Rushmore (LSD-47)
- USS Enterprise (CVN-65)
- USS Dwight D. Eisenhower (CVN-69)
- USS Curtis Wilbur (DDG54)
- USS John S. McCain (DDG56)

The Patience of Tree Farmers

Having just completed the Holidays, I'd like to begin my *Outlook* column with a seasonal tale. Imagine a Christmas tree farmer who has a phenomenal season and sells out every last tree. Although pleased with revenues, he wonders what he will do *next* year. Clearly, if he does not already have additional trees planted in various stages of maturity, he is in big trouble.

We use this Christmas tree farm analogy at Glenair to illustrate our approach to serving today's market—even as we prepare for tomorrow's. Long-term friends of Glenair are surely familiar with the many high-demand products we sell: M85049 backshells, M83513 Micro-D connectors, D38999 Fiber Optics, and so on. But you may not be as familiar with some of the "Christmas trees" planted in our back lot—growing and maturing for future "Holiday seasons."

The MIL-PRF-24758A(SH) "*BlueJacket*" Conduit System detailed in this issue of *QwikConnect* is a perfect example. Glenair has been actively pursuing an improved conduit system design that can meet more stringent UV ratings, higher temperature requirements, expanded fuel immersion tests, FAR 25 smoke emission standards and better overall environmental and EMI performance requirements. We have pursued this project for many years, and numerous designs have undergone performance testing and field trials.

As many of you know, the Navy has begun moving its traditional qualification process away from exactly detailed product specifications (MIL-Specs) to performance-based descriptions called MIL-PRF's. Glenair has been an active participant in the MIL-PRF process, contributing design ideas to improve a broad range of interconnect products used in both topside and below-deck applications. In fact, Glenair has been on the forefront of efforts to produce a new flexible weatherproof EMI conduit system that better addresses the cost and performance requirements of today's Navy.

So, when the new MIL-PRF-24758A(SH) document for topside conduit systems was finally published this past year, Glenair was ready and waiting with designs for better tubing, better jacketing and better fittings and adapters. In relatively short order, we built conforming product, conducted the necessary testing and became the first qualified MIL-PRF-24758A provider. As you now know, we have branded our new conduit system "*BlueJacket*" in honor of the dedicated men and women of the Navy.

It has taken us many years to reach the point where we stand today: blessed and approved to supply the next-generation of Navy ships with conduit protection systems for topside wire and cable applications. I think everyone would agree it has been a long but worthwhile process, and I would like to personally express my congratulations to our team of conduit marketeers including Ralph Hays, Dick Holden and Tim Shantry, a group that truly has the patience of tree farmers.



Christopher J. Toomey
President, Glenair, Inc.

Publisher

Christopher J. Toomey

Executive Editor

Marcus Kaufman

Managing Editor

Carl Foote

Editor/Art Director

Charles W. Belser

Issue Contributors

Dick Holden

Ralph Hays

Jeffrey Bauer

Photographs

Jim Donaldson

Distribution

Terri White

Glenair has been the leading manufacturer and supplier of commercial and Mil-Spec connector accessories since 1956. Building on that foundation, we now offer a dozen, full-spectrum product lines designed to meet every interconnect requirement. From ruggedized military connectors to tactical fiber optic connectors and cables, from EMI conduit systems to Micro-D harness assemblies, from Navy approved composite enclosures to a complete range of connector assembly tools—Glenair does it all. And throughout the years, we've made outstanding customer service our approach to earning customer trust, and to maintaining our position as the industry's best-value interconnect supplier. *QwikConnect* is published occasionally by Glenair, Inc. Printed in U.S.A. All rights reserved. © Copyright 2007 Glenair, Inc.



GLENAIR, INC.

1211 AIR WAY
GLENDALE, CA 91201-2497

TEL: 818-247-6000

FAX: 818-500-9912

EMAIL: sales@glenair.com
www.glenair.com