

927-072-036 PLUG WITH ENVIRONMENTAL CABLE ADAPTER AND BASKET WEAVE CABLE GRIP

How To Order							
Sample Part Number	927-072	-036	-36-66	P1	F9	Y	/A
Series	927-072						
Style	-036 = Basket Weave Cable Grip						
Shell Size - Insert Arrangement	See pages 22- 31						
Contact Type and Plating	P = Pin Contact, S = Socket Contact 1 = Silver Plated, 2 = Gold Plated						
Shell Material and Finish	F9 = Aluminium Alloy, Anodize Hardcoat						
Alternate Key Position	X, Y, Z, W (See Table on page 32) Omit for normal position						
Cable Range	A, B, C (See Table next page)						

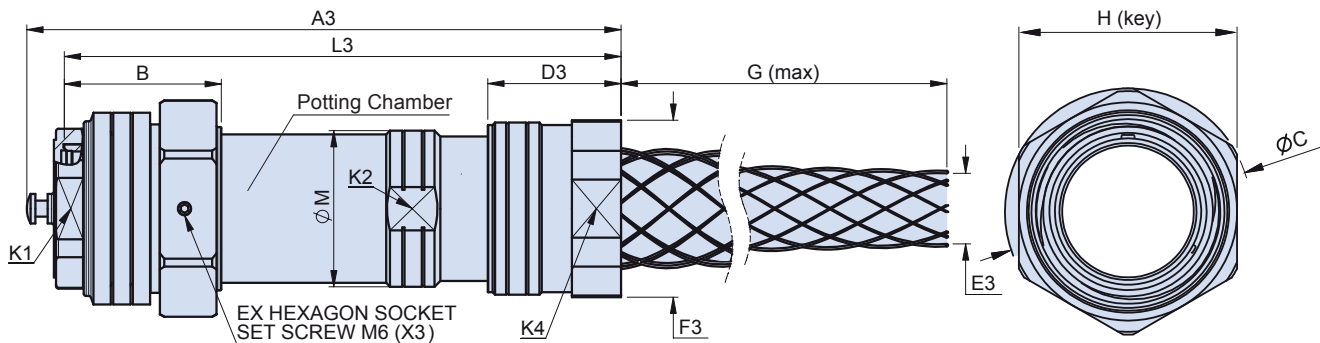

Shell Size	Dimensions													
	A3	B	C	D3	E3		F3	G Max.	H	K1	K2	K4	L3	M
					Min.	Max.								
10SL	*	*	*	*	*	*	*	*	*	*	*	*	*	*
14S	*	*	*	*	*	*	*	*	*	*	*	*	*	*
16	159	63.9	54	35.5	8.0	19.0	42.0	179**	49	30	32	38	143	34.0
18	182	63.9	59	42.7	10.40	23.80	46.0	201**	52	34	36	42	177	38.2
28	224	63.9	72	54.2	17.5	34.1	64.0	239**	65	48	48	60	209	54.0
36	242	63.9	88	52.4	25.60	41.25	72.0	315**	78	60	61	68	227	63.5

(*) Please contact the factory.

(**) Max overall dimension; dimension less than max one, depending on Basket Weave Cable Range.

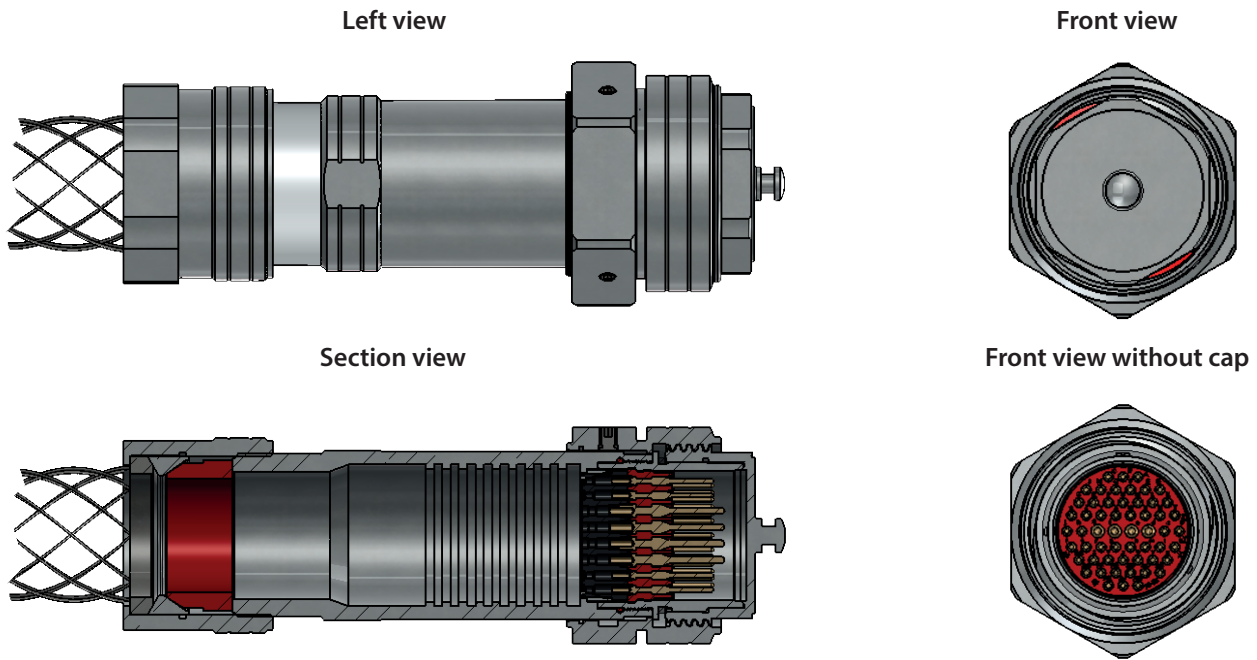

Cable Range Dimensions for Basketweave Cable Grip			
Shell Size	Cable Type (1)	Cable Range Designator	Cable Jacket Range [mm] (2)
36	Unarmored cable	A	39,40 to 41,25
		B	38,90 to 40,50
		C	34,50 to 38,50
		D	31,00 to 34,90
		E	29,40 to 33,30
		F	25,60 to 29,50 (1)
28	Unarmored cable	A	30,10 to 34,10
		B	28,50 to 32,00
		C	25,50 to 29,10
		D	23,40 to 26,60 (1)
		E	21,10 to 23,80
		F	17,50 to 21,40 (1)
18	Unarmored cable	A	19,60 to 23,80
		B	18,00 to 22,20 (1)
		C	15,50 to 19,00
		D	12,70 to 15,90
		E	10,40 to 12,70 (1)
16	Unarmored cable	A	15,50 to 19,00
		B	12,70 to 15,90 (1)
		C	10,40 to 12,70 (1)
		D	8,00 to 9,50 (1)

(1) Armoured cables may be used but the armour cannot be engaged.

(2) It is advisable to use reduction sleeves for lower values of cable diameter within cable range.