



# MIL-DTL-24308

## D-Subminiature Hermetic Connectors

### Style A and Style B Dimensions

#### Dimensions for Flange Style A

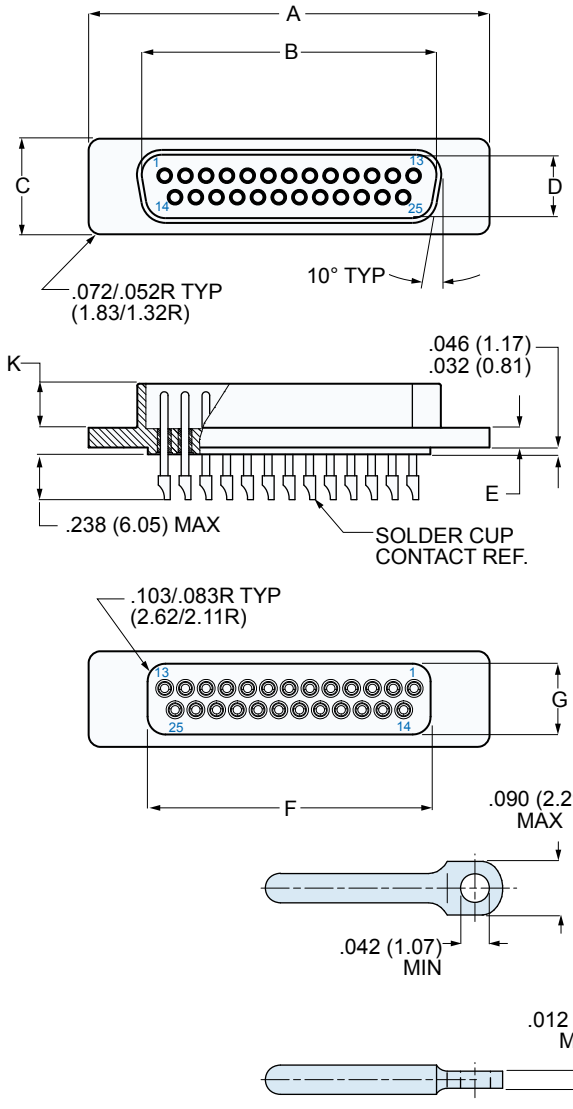

#### Dimensions for Flange Style B

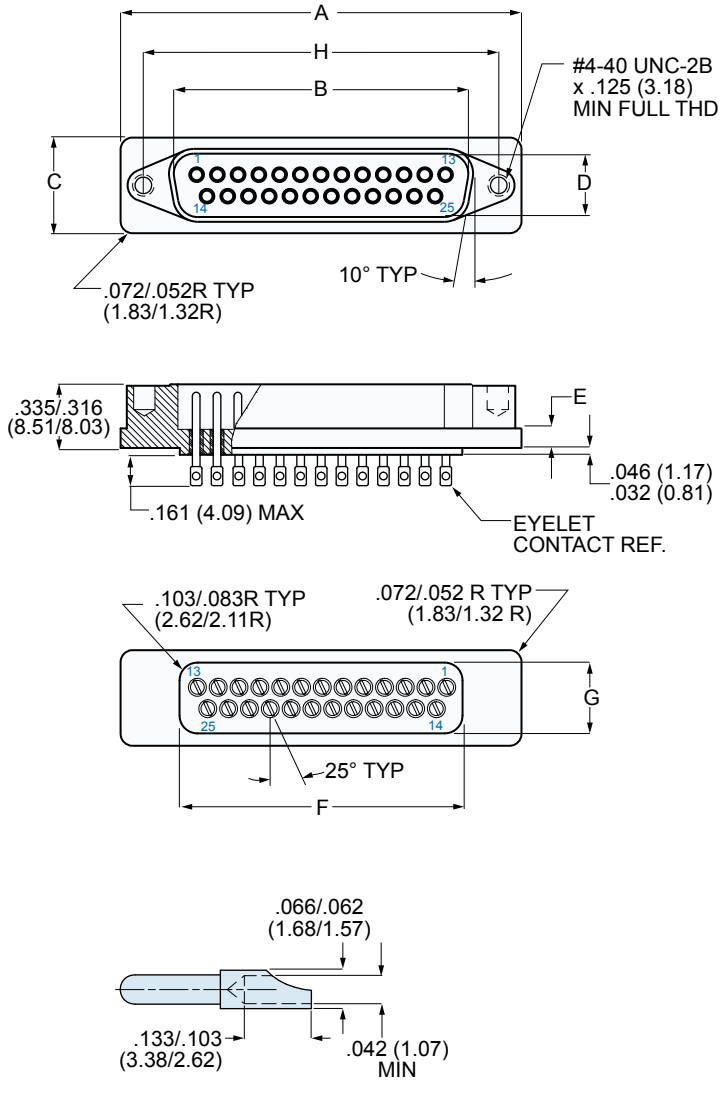

CONTACT STYLE X  
EYELET

CONTACT STYLE P  
SOLDER CUP

Shell Size	A		B		C		D		E		F		G		H		K	
	In.	mm.	In.	mm.	In.	mm.	In.	mm.	In.	mm.	In.	mm.	In.	mm.	In.	mm.	In.	mm.
	±	±	±	±	±	±	±	±	±	±	±	±	±	±	±	±	±	±
1	.015	0.38	.004	0.10	.010	0.25	.004	0.10	.006	0.15	.010	0.25	.010	0.25	.005	0.13	.010	0.25
2	1.213	30.81	.667	16.94	.498	12.65	.330	8.38	.094	2.39	.725	18.42	.369	9.37	.984	24.99	.235	5.97
3	1.541	39.14	.993	25.22	.498	12.65	.330	8.38	.094	2.39	.932	23.67	.369	9.37	1.312	33.32	.235	5.97
4	2.088	53.04	1.535	38.99	.498	12.65	.330	8.38	.103	2.62	1.479	37.57	.369	9.37	1.852	47.04	.230	5.84
5	2.729	69.32	2.183	55.45	.498	12.65	.330	8.38	.103	2.62	2.125	53.98	.369	9.37	2.500	63.50	.230	5.84
5	2.635	66.93	2.079	52.81	.610	15.49	.441	11.20	.103	2.62	2.000	50.80	.500	12.70	2.406	61.11	.230	5.84

Dimensions in Inches (millimeters) are subject to change without notice.