

**How To Order: Commercial**

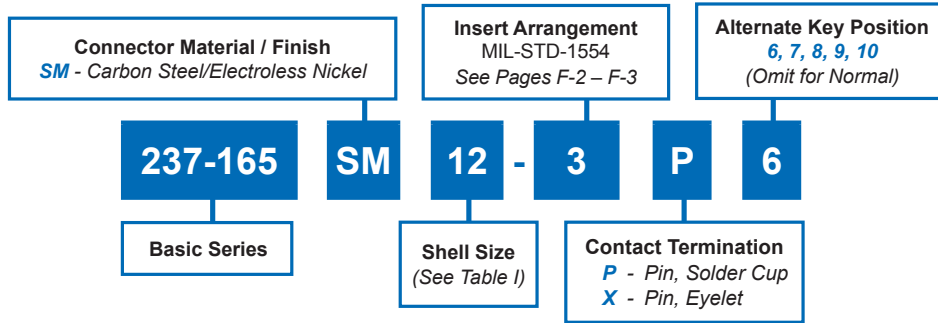

**F**

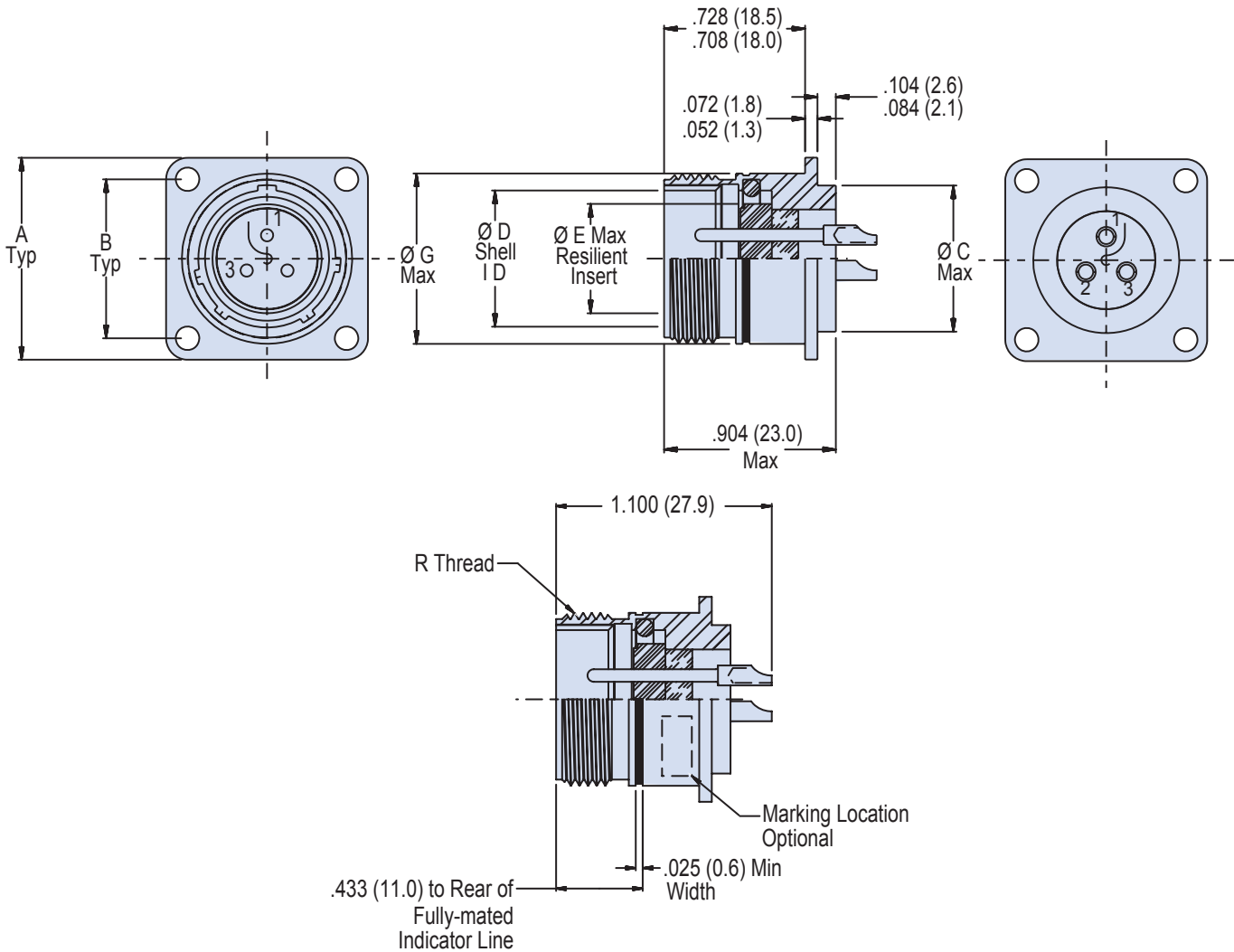

Dimensions in Inches (millimeters) are subject to change without notice.

**237-165**  
**MIL-DTL-26500 Type Hermetic Class Receptacle**  
**MS24264\*\*T\*\*\* Type Square Flange Mount, Threaded Coupling**



MIL-DTL-26500  
Type

F

**TABLE I: Shell Size, Connector Dimensions and Panel Cut-Out**

Shell Size	A	B	Ø C	Ø D Shell I.D.	Ø E Max Resilient Insert	Ø G Max	Ø H Through 4 Places	R Coupling Thread UNEF-2A	Panel Cut-Out Min Ø
8	.812 (20.6)	.594 (15.1)	.500/.494 (12.7/12.5)	.433/.428 (11.0/10.9)	.318 (8.1)	.561 (14.2)	.125/.116 (3.2/2.9)	.562-24	.572 (14.5)
10	.937 (23.8)	.719 (18.3)	.562/.556 (14.3/14.1)	.535/.530 (13.6/13.5)	.394 (10.0)	.696 (17.7)	.125/.116 (3.2/2.9)	.688-24	.706 (17.9)
12	1.031 (26.2)	.812 (20.6)	.750/.744 (19.1/18.9)	.705/.700 (17.9/17.8)	.564 (14.3)	.875 (22.2)	.125/.116 (3.2/2.9)	.875-20	.885 (22.5)
14	1.125 (28.6)	.906 (23.0)	.812/.806 (20.6/20.5)	.774/.769 (19.7/19.5)	.633 (16.1)	.935 (23.7)	.125/.116 (3.2/2.9)	.938-20	.946 (24.0)
16	1.250 (31.8)	.969 (24.6)	.937/.931 (23.8/23.6)	.901/.896 (22.9/22.8)	.760 (19.3)	1.062 (27.0)	.125/.116 (3.2/2.9)	1.062-18	1.072 (27.2)
18	1.343 (34.1)	1.062 (27.0)	1.062/1.056 (27.0/26.8)	1.007/1.002 (25.6/25.5)	.866 (22.0)	1.187 (30.1)	.125/.116 (3.2/2.9)	1.188-18	1.197 (30.4)
20	1.437 (36.5)	1.156 (29.4)	1.187/1.181 (30.1/30.0)	1.132/1.125 (28.8/28.6)	.991 (25.2)	1.312 (33.3)	.125/.116 (3.2/2.9)	1.312-18	1.322 (33.6)
22	1.562 (39.7)	1.250 (31.8)	1.312/1.306 (33.3/33.2)	1.257/1.252 (31.9/31.8)	1.116 (28.3)	1.437 (36.5)	.125/.116 (3.2/2.9)	1.438-18	1.447 (36.8)
24	1.703 (43.3)	1.375 (34.9)	1.437/1.431 (36.5/36.3)	1.382/1.377 (35.1/35.0)	1.241 (31.5)	1.562 (39.7)	.154/.145 (3.9/3.7)	1.562-18	1.572 (39.9)

**APPLICATION NOTES**

- Assembly identified with manufacturer's name and part number, space permitting.
- Glenair 237-165 will mate with any QPL MIL-DTL-26500 type threaded coupling plug of same size, keyway and insert polarization.
- Performance:  
 Hermeticity -  $<10^{-7}$  ccHe/sec @ 1 atmosphere differential  
 Dielectric withstanding voltage - consult factory or MIL-STD-1554  
 Insulation resistance - 5000 megohms min @ 500VDC
- Material/ Finish:  
 Shell—C1215 Steel/Electroless nickel  
 Contacts—52 Nickel alloy/Gold plated  
 Insulators—Glass/NA  
 Seals—fluorosilicone elastomer N.A.
- Metric Dimensions (mm) are indicated in parentheses.

Dimensions in Inches (millimeters) are subject to change without notice.