

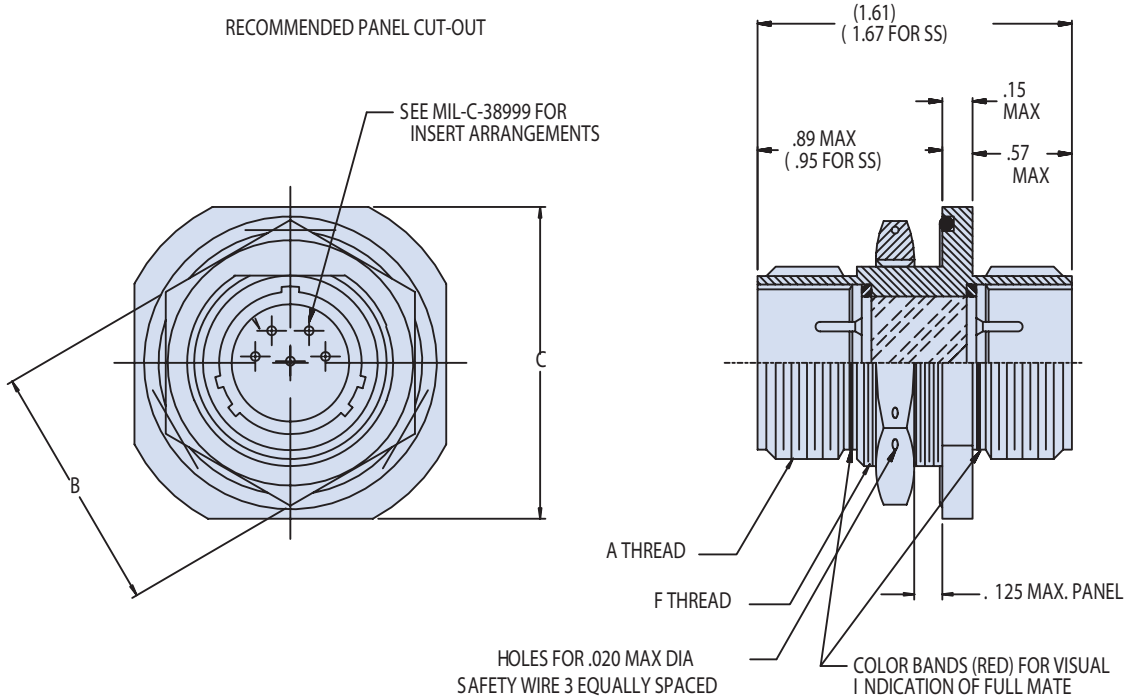

257-093
Jam Nut Mount Hermetic Bulkhead Feed-Thru
with SAE Threads
MIL-DTL-38999 Series III Type

B

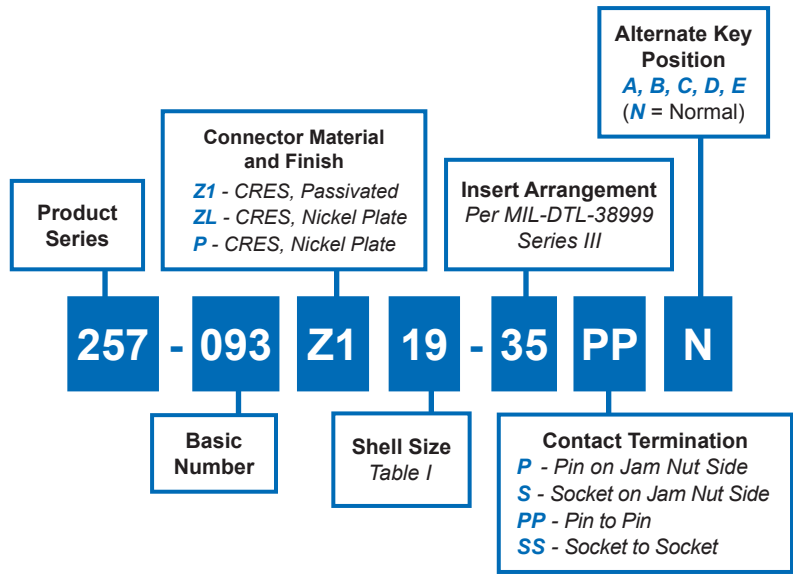

Dimensions in Inches (millimeters) are subject to change without notice.

257-093
Jam Nut Mount Hermetic Bulkhead Feed-Thru
with SAE Threads
MIL-DTL-38999 Series III Type



HERMETIC LEAK RATE MOD CODES	
Designator	Required Leak Rate
-585A	1 x 10 ⁻¹⁰ cc Helium per second
-585B	1 x 10 ⁻⁹ cc Helium per second
-585C	1 x 10 ⁻⁸ cc Helium per second

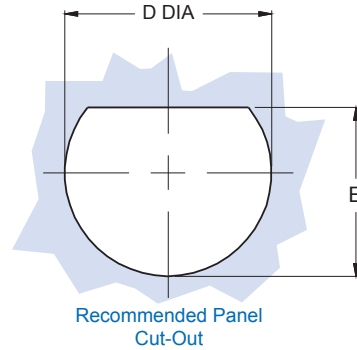

TABLE I: CONNECTOR DIMENSIONS						
SHELL SIZE	A THREAD 0.1 P-0.3L-TS-2	B DIM	C DIM MAX	D DIA	E DIM	F THREAD CLASS 2A
9	0.625	.875(22.2)	1.09(27.7)	.693 (17.60)	.657 (16.70)	11/16-24 UNEF
11	0.750	1.000(25.4)	1.28(32.5)	.825 (20.96)	.771 (19.59)	13/16-20 UNEF
13	0.875	1.250(31.8)	1.40(35.6)	1.010 (25.65)	.955 (24.26)	1-20 UNEF
15	1.000	1.375(34.9)	1.53(38.9)	1.135 (28.83)	1.085 (27.56)	1 1/8-18 UNEF
17	1.187	1.500(38.1)	1.66(42.2)	1.260 (32.01)	1.210 (30.73)	1 1/4-18 UNEF
19	1.250	1.625(41.3)	1.84(46.7)	1.385 (35.18)	1.335 (33.91)	1 3/8-18 UNEF
21	1.375	1.750(44.5)	1.97(50.5)	1.510 (38.35)	1.460 (37.08)	1 1/2-18 UNEF
23	1.500	1.875(47.6)	2.09(53.1)	1.635 (41.53)	1.585 (40.26)	1 5/8-18 UNEF
25	1.625	2.000(50.8)	2.21(56.1)	1.760 (44.70)	1.710 (43.43)	1 3/4-18 UNEF

APPLICATION NOTES

- | | |
|---|---|
| <ol style="list-style-type: none"> 1. Assembly identified with manufacturer's name and PN, space permitting. 2. For pin/pin and socket/socket, symmetrical layouts only, consult factory for available insert arrangements. 3. Electrical safety limits must be established by user, peak voltage, switching surge, transient, etc. should be used to determine the safety of the application. | <ol style="list-style-type: none"> 4. Material/Finish:
Shell, lock ring, jam nut—stainless steel/passivate
Contacts—alloy 52/gold plate
Sockets—copper alloy/gold plate
Hermetic Insulator—full glass/N.A.
Socket Insulator—rigid dielectric/N.A.
Seals—fluorosilicone/ N.A.
Hermeticity -1x10⁻⁷ cc/second 5. Metric dimensions (mm) are indicated in parentheses. |
|---|---|

Dimensions in Inches (millimeters) are subject to change without notice.