

**Metal Guardian System bulkhead feed-thru fitting**

**How To Order**

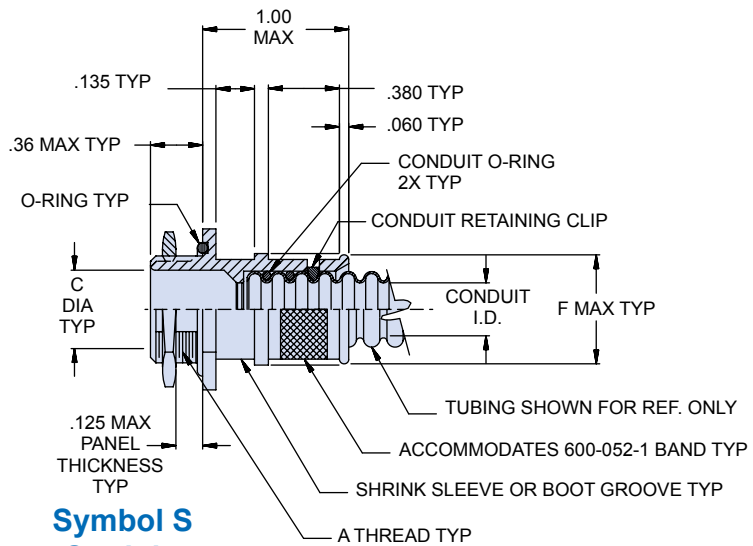
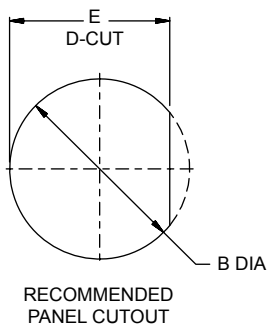
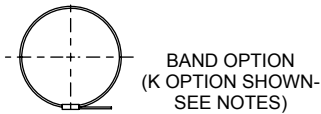
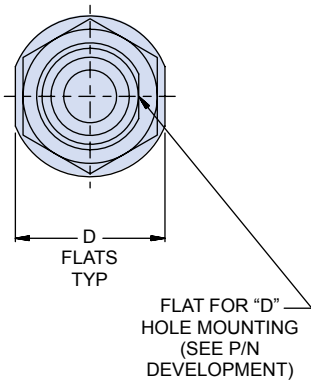
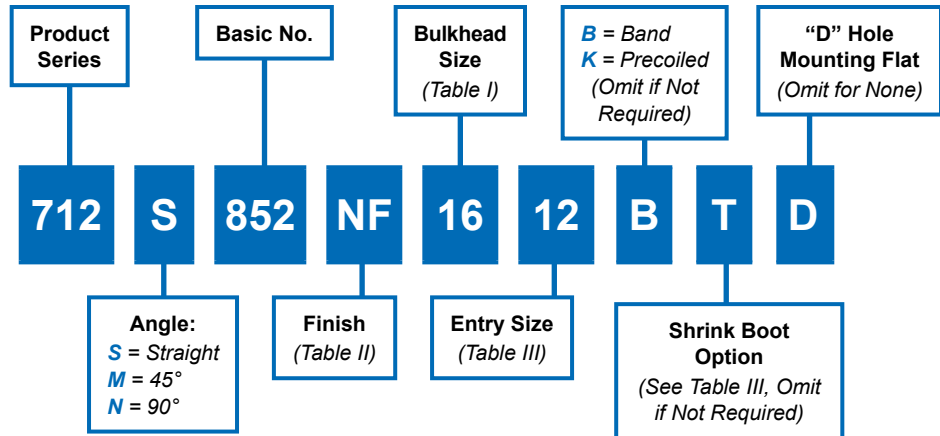

**Symbol S**  
**Straight**

**Material and Finish**

Adapters, elbows: See Table II  
O-rings: Silicone/NA  
Retaining Clip: High Grade Engineering Thermoplastic/NA

**Tools, Accessories and Assembly notes**

Tubing shown for Reference only.  
Glenair 600 Series backshell assembly tools are recommended for assembly and installation.  
Glenair Assembly procedure AP74-010 is recommended for adapter to conduit termination.  
Conduit retaining clip and O-ring to be supplied unassembled.

712-852

**Metal EMI/RFI Environmental Bulkhead Feed-Thru Fitting  
for Series 72 Annular Convolute Tubing**



Series 72  
Guardian

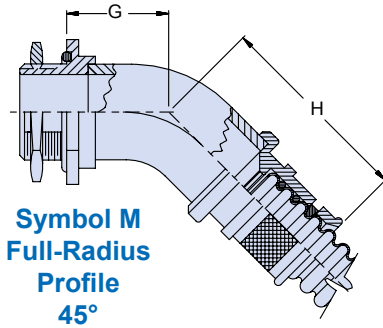

Table I						
Bulkhead Size	A Thread Class 2A	B $+0.015$ $-0.000$	C Dia	D Flats	E $+0.010$ $-0.000$	Max Entry Size
06	3/8-32 UNEF	0.380 (9.7)	0.188 (4.8)	0.625 (15.9)	0.323 (8.2)	09
08	7/16-28 UNEF	0.443 (11.3)	0.250 (6.4)	0.688 (17.5)	0.385 (9.8)	12
09	1/2-20 UNF	0.505 (12.8)	0.281 (7.1)	0.750 (19.1)	0.448 (11.4)	12
10	1/2-20 UNF	0.505 (12.8)	0.312 (7.9)	0.750 (19.1)	0.448 (11.4)	12
12	9/16-24 UNEF	0.568 (14.4)	0.375 (9.5)	0.812 (20.6)	0.510 (13.0)	16
14	5/8-24 UNEF	0.63 (16.0)	0.438 (11.1)	0.875 (22.2)	0.573 (14.6)	16
16	11/16-24 UNEF	0.693 (17.6)	0.500 (12.7)	0.937 (23.8)	0.635 (16.1)	20
20	13/16-20 UNEF	0.818 (20.8)	0.625 (15.9)	1.062 (27.0)	0.760 (19.3)	20
24	15/16-20 UNEF	0.943 (24.0)	0.750 (19.1)	1.250 (31.8)	0.885 (22.5)	24
28	1 1/16-18 UNEF	1.068 (27.1)	0.875 (22.2)	1.375 (34.9)	1.010 (25.7)	32
32	1 3/16-18 UNEF	1.193 (30.3)	1.000 (25.4)	1.562 (39.7)	1.135 (28.8)	32
40	1 7/16-18 UNEF	1.443 (36.7)	1.250 (31.8)	1.875 (47.6)	1.385 (35.2)	40

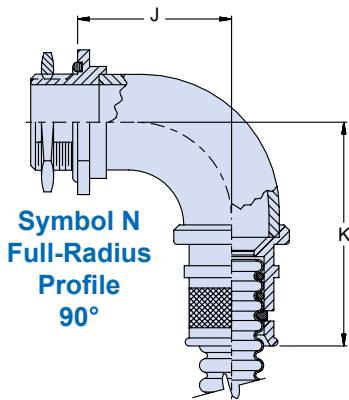

Table II		
Sym	Material	Finish Description
M	Aluminum	Electroless Nickel
MT		Nickel-PTFE
NF		Cad/Olive Drab over Electroless Nickel
ZN		Zinc Nickel/Olive Drab over Electroless Nickel
ZNU		Zinc Nickel/Black over Electroless Nickel
ZI	Stainless Steel	Passivate

Table III								
Entry Size	F Max	Conduit I.D.		G Max	H Max	J Max	K Max	Shrink Boot Ref
		Min	Max					
06	0.53 (13.5)	0.16 (4.1)	0.19 (4.8)	0.50 (12.7)	1.02 (25.9)	0.68 (17.3)	1.20 (30.5)	770-001S103
09	0.63 (16.0)	0.24 (6.1)	0.28 (7.1)	0.53 (13.5)	1.04 (26.4)	0.75 (19.1)	1.26 (32.0)	770-001S103
12	0.73 (18.5)	0.33 (8.4)	0.37 (9.4)	0.53 (13.5)	1.04 (26.4)	0.75 (19.1)	1.26 (32.0)	770-001S104
16	0.86 (21.8)	0.45 (11.4)	0.50 (12.7)	0.55 (14.0)	1.07 (27.2)	0.81 (20.6)	1.33 (33.8)	770-001S104
20	0.98 (24.9)	0.57 (14.5)	0.62 (15.7)	0.61 (15.5)	1.12 (28.4)	0.93 (23.6)	1.45 (36.8)	770-001S105
24	1.15 (29.2)	0.69 (17.5)	0.75 (19.1)	0.63 (16.0)	1.15 (29.2)	1.00 (25.4)	1.51 (38.4)	770-001S106
28	1.27 (32.3)	0.81 (20.6)	0.87 (22.1)	0.68 (17.3)	1.20 (30.5)	1.12 (28.4)	1.64 (41.7)	770-001S107
32	1.40 (35.6)	0.93 (23.6)	1.00 (25.4)	0.71 (18.0)	1.22 (31.0)	1.18 (30.0)	1.70 (43.2)	770-001S107
40	1.62 (41.1)	1.18 (30.0)	1.25 (31.8)	0.76 (19.3)	1.28 (32.5)	1.31 (33.3)	1.83 (46.5)	770-001S107