

GTK2000 Glenair Fiber Optic Testing Kit for GHD Fiber Optic Connection Systems



Test Probes
and Kits

Fiber optic testing kit for fiber optic connection systems

Traditional optical test harnesses are expensive and easily contaminated in normal use. The Glenair fiber optic testing kit utilizes a special probe device in conjunction with our precise-mating test adapter, to provide a complete solution to optical test and measurement. The GTK-2000 comes with a power meter, source meter, test probes and a test probe calibration adapter. For accurate results, the test probe calibration adapter will “zero out” your meters.

The Glenair patented test probe design provides less than 1.0 dB insertion loss, and is used with test probe adapters and a calibration feedthrough to perform efficient measurements of fiber optic cable performance. The kit accommodates all standard fiber sizes and multiple fiber optic connection systems

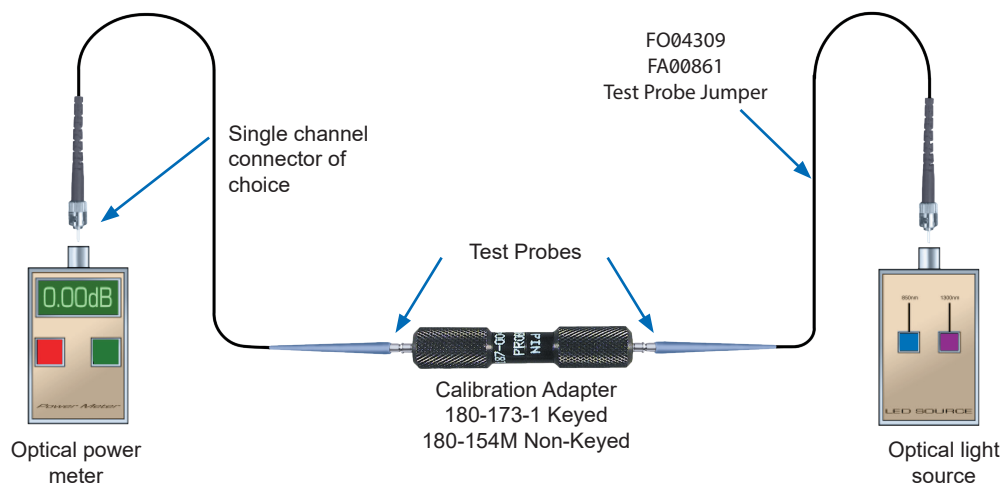
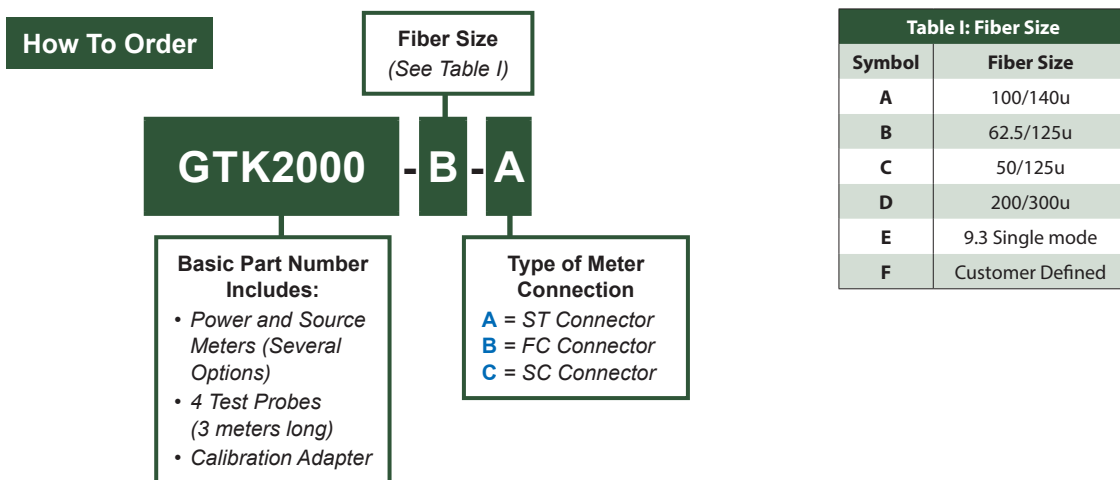

Note:

Replacement calibration adapters and test probe jumpers sold separately.
 Test probe connector adapters sold separately
 The fiber optic test probe kit supports GHD fiber optic connection systems. For test kits for other Glenair high performance fiber optic connection systems, please consult factory.

Effective use of Glenair fiber optic test equipment

Step 1: "Zeroing-out" optical power meter and light source

The first step in using the optical test probes is to install each end of the probe cable assembly to the optical power meter and light source. Next, insert each probe into the calibration adapter.

The test probe loss can now be recorded as a reference measurement or may be "zeroed-out."

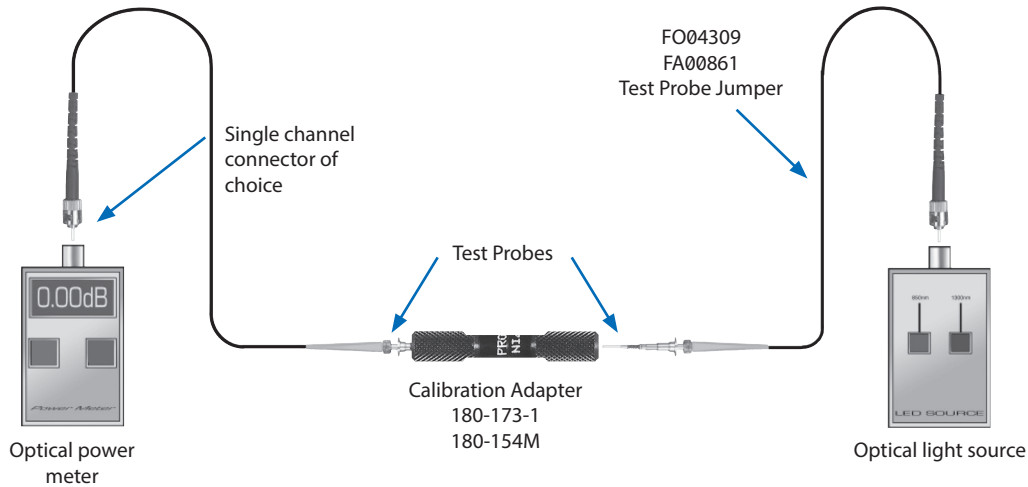

Step 2: Performing optical measurement

Now you are ready to perform optical measurements on the fiber optic cable harness. First, select the proper Glenair Probe Adapter.

Now, mate or couple the adapters to each end of the cable harness. Next, insert each probe in the appropriate channel to be tested by pushing on the knurled area on the test probes. Read and record the optical performance.

To measure the next channel, remove the test probe by pushing on the large diameter of the test probe. The probe can now be removed and inserted into the next channel. Re-establishing or verification of reference can be performed at any time by following Step 1.

