

440-143

Composite Ultra Low Profile EMI/RFI Micro-Banding Backshell with Qwik-Ty, Shrink Boot Porch and Self-Locking Rotatable Coupling

A

CONNECTOR DESIGNATOR:	
F	MIL-DTL-38999 Series I, II
H	MIL-DTL-38999 Series III and IV
SELF-LOCKING	
ROTATABLE COUPLING	
ULTRA LOW PROFILE	

Angle and Profile <i>S</i> - Straight <i>A</i> - 90° Low Profile, Std <i>T</i> - 45° Elbow <i>E</i> - 90° Low Profile, Split <i>W</i> - 90° Low Profile, Solid	Cable Entry (See Table II) Omit for <i>E</i> and <i>W</i> Option Only	Drain Hole Option (Omit "D" if not required)
Product Series 440 - EMI/RFI Non-Environmental Micro-Banding Backshells	Basic Part Number	Shrink Boot Option Shrink boot supplied with <i>T</i> option O-Ring will not be supplied with Connector Designator A (Omit for none)
Finish Symbol (See Table III)		

440 H S 143 XM 15 09 D B T S

Connector Designator <i>A, F or H</i> (See Table I) See Note 1	Connector Shell Size (See Table I) See Note 1	Band Option Band supplied with <i>B</i> option (Omit for none)	Shield Termination Slot (Omit for none)
--	--	--	---

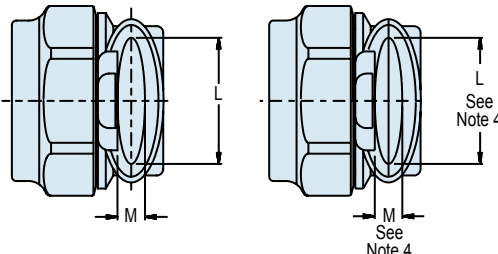
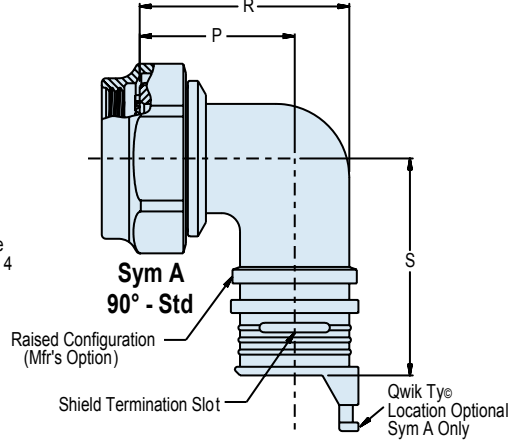
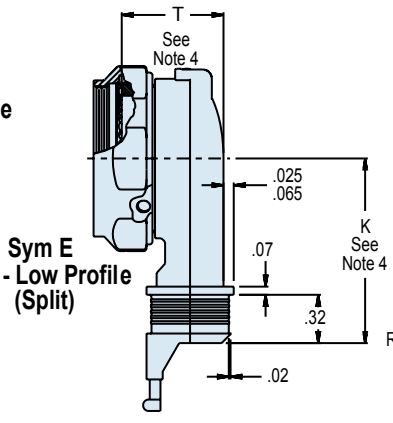
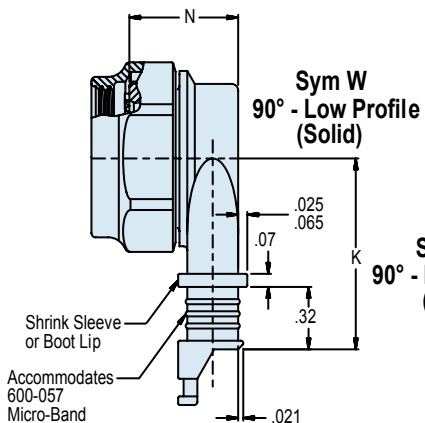
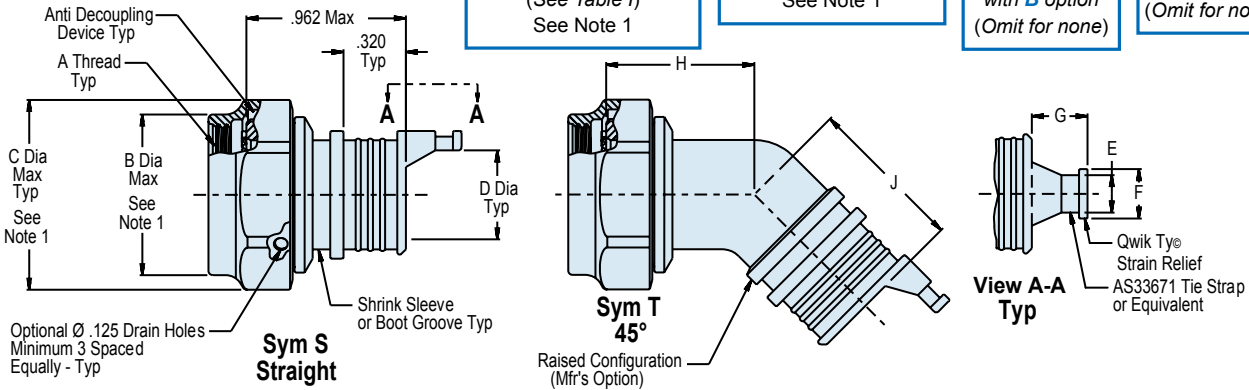

440-143
Composite Ultra Low Profile EMI/RFI
Micro-Banding Backshell with Qwik-Ty, Shrink Boot Porch
and Self-Locking Rotatable Coupling



TABLE I: SHELL SIZE

Shell Size		Entry Code Available for Straight, 45° and 90° Std Configuration	K ± .03	L	M	N Max	P ±.09	R ±.09	S Max	T Max
A & F	H									
08	09	04	1.042 (26.5)	.304 (7.7)	.160 (4.1)	.630 (16.0)	.690 (17.5)	.880 (22.4)	1.360 (34.5)	.810 (20.6)
10	11	05	1.107 (28.1)	.432 (11.0)	.174 (4.4)	.660 (16.8)	.750 (19.1)	1.000 (24.5)	1.420 (36.1)	.810 (20.6)
12	13	07	1.174 (29.8)	.546 (13.9)	.195 (5.0)	.720 (18.3)	.810 (20.6)	1.130 (28.7)	1.480 (37.6)	.820 (20.8)
14	15	09	1.241 (31.5)	.670 (17.0)	.315 (8.0)	.830 (21.1)	.880 (22.4)	1.310 (33.3)	1.550 (39.4)	.880 (22.4)
16	17	05 and 11	1.305 (33.1)	.796 (20.2)	.385 (9.8)	.910 (23.1)	.940 (23.9)	1.380 (35.1)	1.610 (40.9)	.930 (23.6)
18	19	07 and 13	1.371 (34.8)	.902 (22.9)	.445 (11.3)	.930 (23.6)	.970 (24.6)	1.440 (36.6)	1.640 (41.7)	.990 (25.1)
20	21	09 and 15	1.438 (36.5)	1.027 (26.1)	.525 (13.3)	1.040 (26.4)	1.060 (26.9)	1.630 (41.4)	1.730 (43.9)	1.060 (26.9)
22	23	11 and 16	1.505 (38.2)	1.152 (29.3)	.595 (15.1)	1.120 (28.4)	1.130 (28.7)	1.750 (44.5)	1.800 (45.7)	1.130 (28.7)
24	25	07, 13 and 17	1.572 (39.9)	1.276 (32.4)	.655 (16.6)	1.180 (30.0)	1.190 (30.2)	1.880 (47.8)	1.860 (47.2)	1.050 (26.7)
24*	25		1.850 (47.0)	1.460 (37.1)	.450 (11.4)	1.020 (26.0)				1.050 (26.7)

*See Note 4

TABLE II: CABLE ENTRY

Entry Code	D ± .030	E Ref	F Ref	G Ref	H ± .060	J ± .090
04	.250 (6.4)	.187 (4.7)	.312 (7.9)	.512 (13.0)	.720 (18.3)	.870 (22.1)
05	.310 (7.9)	.187 (4.7)	.312 (7.9)	.512 (13.0)	.750 (19.1)	.930 (23.6)
07	.440 (11.2)	.187 (4.7)	.312 (7.9)	.512 (13.0)	.750 (19.1)	1.00 (25.4)
09	.560 (14.2)	.219 (5.6)	.375 (9.5)	.630 (16.0)	.760 (19.3)	1.03 (26.2)
11	.680 (17.3)	.219 (5.6)	.375 (9.5)	.630 (16.0)	.780 (19.8)	1.05 (26.7)
13	.810 (20.6)	.219 (5.6)	.375 (9.5)	.630 (16.0)	.790 (20.1)	1.06 (26.9)
15	.940 (23.9)	.219 (5.6)	.375 (9.5)	.630 (16.0)	.820 (20.8)	1.09 (27.7)
16	1.000 (25.4)	.219 (5.6)	.375 (9.5)	.630 (16.0)	.860 (21.8)	1.13 (28.7)
17	1.160 (29.5)	.250 (6.4)	.437 (11.1)	.630 (16.0)	.890 (22.6)	1.16 (29.5)

TABLE III: FINISH

Symbol	Finish Description
XM	2000 Hour Corrosion Resistant Electroless Nickel
XMT	2000 Hour Corrosion Resistant Ni-PTFE, Nickel-Fluorocarbon Polymer. <i>1000 Hour Grey™</i>
XW	2000 Hour Corrosion Resistant Cadmium/Olive Drab over Electroless Nickel

NOTES

1. 770-001S**-0 shrink boot supplied with T option. See shrink boot product page for more details.
2. Coupling nut supplied unplated.
3. See Table I in Intro for front-end dimensional details.
4. For Sym "E" low profile split shell sizes 24 and 25 dimensions, use indicator row in Table I.