

850-014
Size 8 Pin Contact
High Power



Special Purpose

#8 High Power Pin Contact



Mating End Size	Wire Accommodations	Glenair Part Number
8	8 AWG	850-014

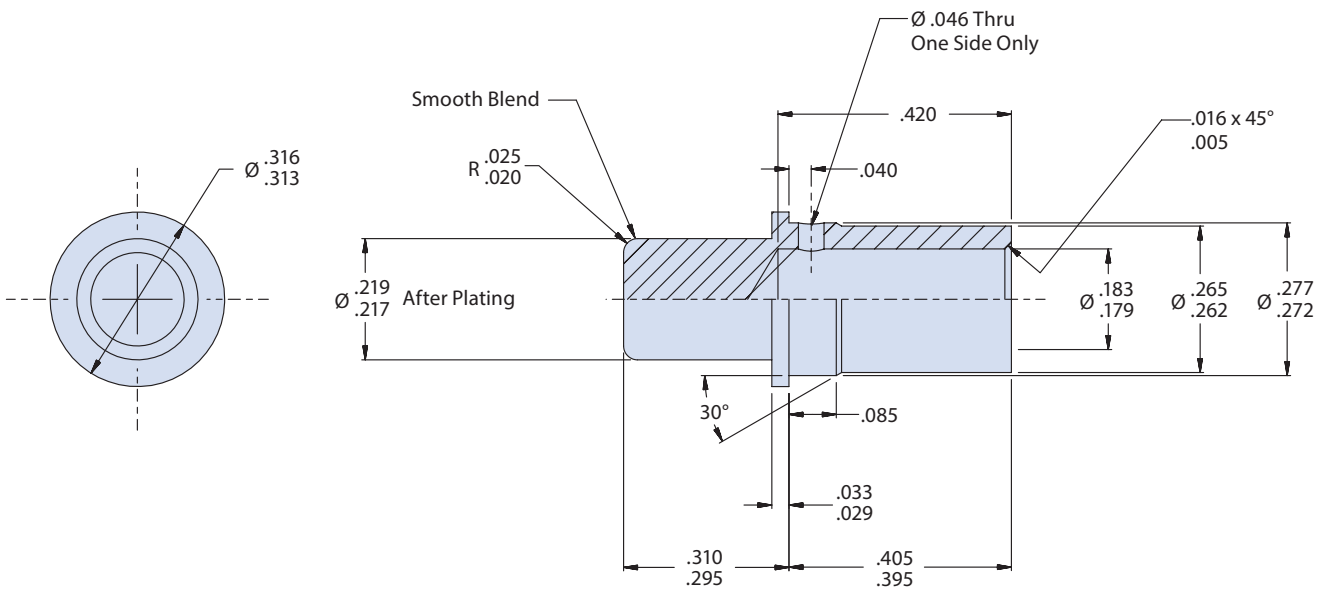

Material and Finish

Contact Body: Copper alloy, plated with 50 microinches gold per ASTM B488 Type II code C over 50–100 microinches nickel IAW SAE AMS-QQ-N-290, class II

Crimp Tools and Insertion/Extraction Tools

Crimp Tool: 859-025 (M22520/23-01)

Crimp Die: 859-026 (M22520/23-02)

Locator: 859-046 (Daniels WA23-395L)

or Spring Locator (recommended): 859-164 (Daniels WA23-395SLL)

Consult factory for cable accommodation and respective tool compatibility.

Notes

For use with MM, SuperNine (233-217 and 233-218).

D