

MIGHTY MOUSE TO ALPHALINK FLEX JUMPERS

Contact arrangements • dimensions • alternate key positions



Mighty Mouse to AlphaLink Flex Jumpers

Glenair Series 801 double-start ACME thread and Series 804 quick-disconnect Mighty Mouse receptacles in 8 contact arrangements terminated with rugged polyimide-based flex to high-performance AlphaLink SL board level connectors.



Mighty Mouse to AlphaLink flex jumper

Recommended Mighty Mouse I/O to AlphaLink Contact Arrangements*

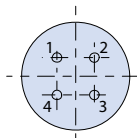

6-4

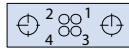

4 Contacts

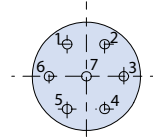

6-7

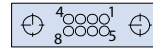

8 Contacts

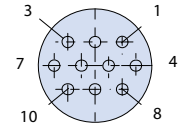

7-10

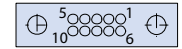

10 Contacts

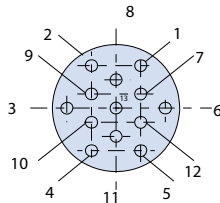

8-13



16 Contacts

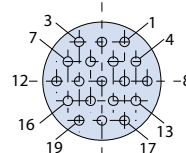

9-19



20 Contacts

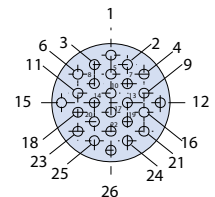

10-26



28 Contacts

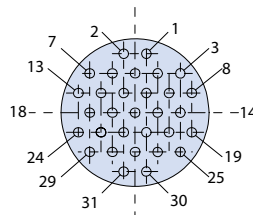

11-31

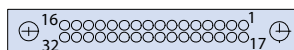

32 Contacts

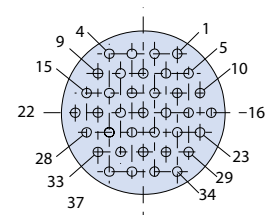

12-37
(13-37)



40 Contacts

*These are recommended contact arrangements only, but do offer best availability. Contacts are mapped 1-to-1 from I/O to B/L connector (unused B/L contacts not connected). For alternative wire schedules, please consult factory.

E

MIGHTY MOUSE TO ALPHALINK® FLEX JUMPERS

Contact arrangements • dimensions • alternate key positions



Table IV Available I/O Insert Arrangement and B/L Assembly Pairs*			
Ins. Arr.	I/O Contact		B/L Layout
	Size	Qty	
6-4	23	4	4
6-7	23	7	8
7-10	23	10	10
8-13	23	13	16
9-19	23	19	20
10-26	23	26	28
11-31	23	31	32
12-37/13-37	23	37	40

* Contacts mapped 1-to-1 from I/O to B/L connector (unused B/L contacts not connected). For alternative wire schedules, please consult factory.

Table V - B/L Connector Dimensions		
Layout	AA	BB
4	.527 (13.4)	.350 (8.9)
8	.627 (15.9)	.450 (11.4)
10	.677 (17.2)	.500 (12.7)
16	.827 (21.0)	.650 (16.5)
20	.927 (23.5)	.750 (19.1)
28	1.127 (28.6)	.950 (24.1)
32	1.227 (31.2)	1.050 (26.7)
40	1.427 (36.2)	1.250 (31.8)

Table VII I/O Connector Alternate Key and Keyway Position		
Position	A°	B°
A	150°	210°
B	75°	210°
C	95°	230°
D	140°	275°
E	75°	275°
F	95°	210°

MATERIALS AND FINISHES

B/L connector shell: Aluminum alloy. I/O shell, jam nut: See Table I
 Insulator: High-temperature thermoplastic rated UL94 V-0
 Seals, grommet, O-ring: Fluorosilicone
 Contacts: Copper Alloy/Gold Plated
 Potting: Epoxy

NOTES

Input/Output Series 801 and 804 Mighty Mouse connectors:
 I/O connector will mate with all quick-coupling high density plug connectors with same polarization and opposite contact gender
 Contacts mapped 1-to-1 from I/O to B/L connector (unused B/L contacts not connected). For alternative wire schedules, please consult factory.

Board Level AlphaLink® SL connector:

B/L AlphaLink® SL connectors are built in accordance with Glenair drawing 171-134-02
 B/L connectors are paired with I/O connectors as shown on Table IV

Flex Performance:

Shielding - EMI shielding film.
 Bend radius is 6 to 10 times the flex thickness.
 Typical flex will be .01 ± .005 thick, rugged, potted, polyimide-based flex.

Flex cables are terminated from the I/O connector to the B/L connector on a 1 to 1 connection (unused B/L contacts are not connected)

Workmanship shall be IAW IPC-6013, Class 2.

Consult factory for more options and/or special designs and requirements



Rear-panel-mount environmental double-start ACME thread connector to AlphaLink SL flex jumper

801-110

SERIES 801 MIGHTY MOUSE INPUT/OUTPUT (I/O) JAM NUT OR SQUARE FLANGE RECEPTACLE TO ALPHALINK SL SPRING LOADED CONTACT BOARD LEVEL (B/L) CONNECTOR

How To Order 801-110										
Sample Part Number	801-110	-07	NF	10-26	P	A	-2	T	-6	S
Series / Basic Part No.	Series 801 Mighty Mouse I/O receptacle to Series 171 AlphaLink SL									
I/O Connector Style	02 = Square flange receptacle 07 = Jam nut receptacle									
I/O Material / Finish	See Table I									
I/O Insert Arrangement	6-4, 6-7, 7-10, 8-13, 9-19, 10-26, 11-31, 13-37 (See Table IV)									
I/O Contact Gender	P = Pin S = Socket									
I/O Alternate Polarization	A, B, C, D, E, F (See Table VII)									
AlphaLink Finish	2 = Nickel 5 = Gold									
AlphaLink Hardware Option	T = Threaded thru hole Omit for thru hole									
Assembly Length	3 = 3.00 ± .05 inches 6 = 6.00 ± .05 inches 12 = 12.00 ± .05 inches									
Optional Shielding	S = With shielding Omit for none									

E

Table VI - Series 801 I/O Connector Dimensions and Cutouts							
Shell Size	A Sq	B Bsc	Ø C	Ø D	E Flat	F Flat	J Holes
6	.590 (15.0)	.423 (10.7)	.750 (19.1)	.635 (16.1)	.595 (15.1)	.410 (10.4)	.096 (2.4) .091 (2.3)
7	.650 (16.5)	.483 (12.3)	.850 (21.6)	.755 (19.2)	.723 (18.4)	.536 (13.6)	
8	.712 (18.1)	.545 (13.8)	.938 (23.8)	.755 (19.2)	.723 (18.4)	.536 (13.6)	
9	.850 (21.6)	.607 (15.4)	1.125 (28.6)	.830 (21.1)	.790 (20.1)	.596 (15.1)	.130 (3.3) .126 (3.2)
10	.890 (22.6)	.670 (17.0)	1.188 (30.2)	.890 (22.6)	.855 (21.7)	.658 (16.7)	
11	.935 (23.7)	.715 (18.2)	1.250 (31.8)	.960 (24.4)	.925 (23.5)	.718 (18.2)	
13	1.030 (26.2)	.812 (20.6)	1.375 (34.9)	1.078 (27.4)	1.044 (26.5)	.845 (21.5)	

Table VI (continued) - Series 801 I/O Connector Dimensions and Cutouts						
Shell Size	K Thread	L Thread	Ø M	N Flat	Ø P	Ø R
6	.3750-.05P-.1L-2A	.4375-28 UNEF-2A	.330 (8.4)	0.418 (10.6) 0.414 (10.5)	.448 (11.4)	.390 (9.9)
7	.4375-.05P-.1L-2A	.5625-32 UN-2A	.432 (11.0)	0.544 (13.8) 0.540 (13.7)	.573 (14.6)	.450 (11.4)
8	.5000-.05P-.1L-2A	.5625-32 UN-2A	.493 (12.5)	0.544 (13.8) 0.540 (13.7)	.573 (14.6)	.510 (13.0)
9	.5625-.05P-.1L-2A	.6250-28 UN-2A	.551 (14.0)	0.604 (15.3) 0.600 (15.2)	.635 (16.1)	.575 (14.6)
10	.6250-.05P-.1L-2A	.6875-28 UN-2A	.620 (15.7)	0.668 (17.0) 0.664 (16.9)	.698 (17.7)	.640 (16.3)
11	.6875-.05P-.1L-2A	.7500-28 UN-2A	.662 (16.8)	0.728 (18.5) 0.724 (18.4)	.760 (19.3)	.700 (17.8)
13	.8125-.1P-.2L-2A	.8750-28 UN-2A	.703 (17.9)	0.853 (21.7) 0.849 (21.6)	.885 (22.5)	.825 (21.0)

Rear-panel-mount environmental double-start ACME thread connector to AlphaLink SL flex jumper

801-110

07 - JAM NUT MOUNT I/O RECEPTACLE

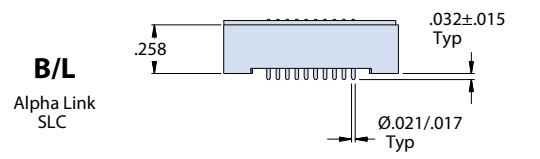
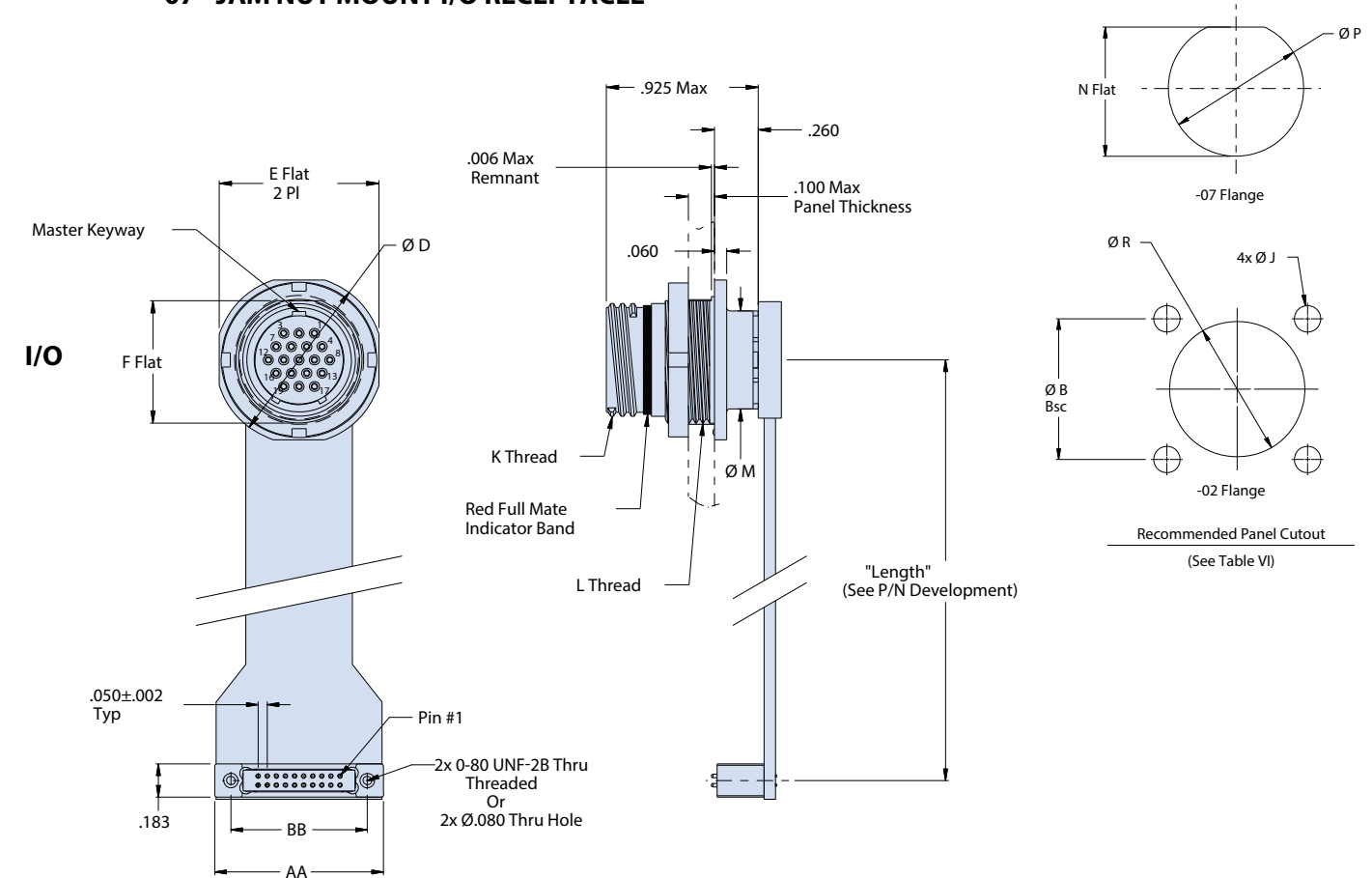

Tag/bag Label

(Part Number)
(Job Number)
Glenair 06324
1 Each D/C (YYWW)

02 - SQUARE FLANGE I/O RECEPTACLE

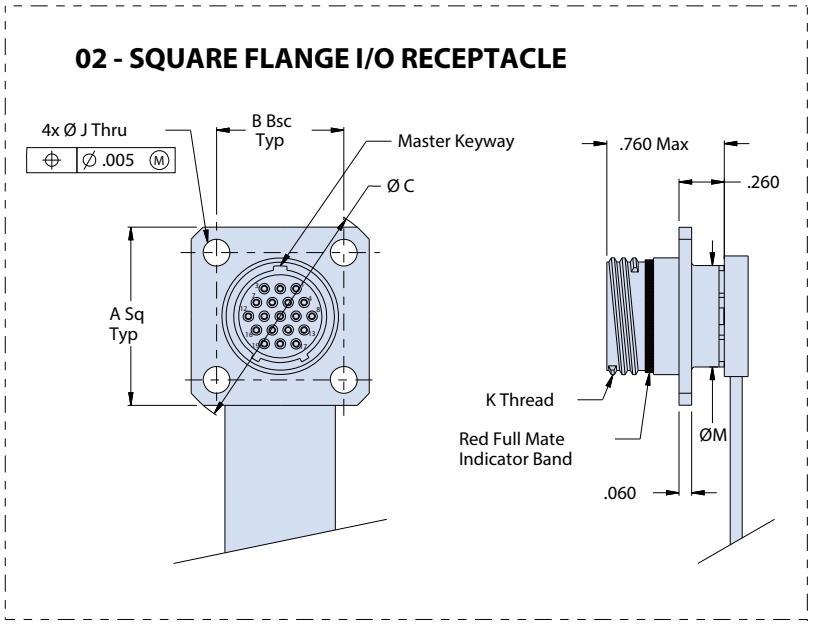

MIGHTY MOUSE TO ALPHALINK FLEX JUMPERS

Rear-panel-mount environmental push-pull connector to AlphaLink SL flex jumper



804-110

SERIES 804 MIGHTY MOUSE INPUT/OUTPUT (I/O) JAM-NUT RECEPTACLE TO ALPHALINK SL SPRING LOADED CONTACT BOARD LEVEL (B/L) CONNECTOR

How To Order 804- 110										
Sample Part Number	804-110	-07	NF	10-26	P	A	-2	T	-6	S
Series / Basic Part No.	Series 804 Mighty Mouse I/O receptacle to Series 171 AlphaLink SL									
I/O Connector Style	07 = Jam nut receptacle									
I/O Material / Finish	See Table I									
I/O Insert Arrangement	6-4, 6-7, 7-10, 8-13, 9-19, 10-26, 11-31, 13-37 (See Table IV)									
I/O Contact Gender	P = Pin S = Socket									
I/O Alternate Polarization	A, B, C, D, E, F (See Table VII)									
AlphaLink Finish	2 = Nickel 5 = Gold									
AlphaLink Hardware Option	T = Threaded thru hole Omit for thru hole									
Assembly Length	3 = 3.00 ± .05 inches 6 = 6.00 ± .05 inches 12 = 12.00 ± .05 inches									
Optional Shielding	S = With shielding Omit for none									

E

Table VI - Series 804 I/O Connector Dimensions and Cutouts								
Shell Size	A Thread	Ø B	Ø C	D-Flat	Ø E	Ø F	M Flat	Ø N
6	.5000-32 UN-2A	.730 (18.5)	.625 (15.9)	.467 (11.9)	.330 (8.4)	.483 (12.3)	.479 (12.2) .475 (12.1)	.510 (13.0)
7	.6250-28 UN-2A	.910 (23.1)	.750 (19.1)	.594 (15.1)	.432 (11.0)	.570 (14.5)	.606 (15.4) .601 (15.3)	.635 (16.1)
8	.6250-28 UN-2A	.955 (24.3)	.750 (19.1)	.594 (15.1)	.493 (12.5)	.593 (15.1)	.606 (15.4) .601 (15.3)	.635 (16.1)
9	.6875-28 UN-2A	1.000 (25.4)	.812 (20.6)	.655 (16.6)	.551 (14.0)	.685 (17.4)	.667 (16.9) .663 (16.8)	.695 (17.7)
10	.7500-28 UN-2A	1.085 (27.6)	.875 (22.2)	.721 (18.3)	.620 (15.7)	.725 (18.4)	.734 (18.6) .729 (18.5)	.760 (19.3)
11	.8125-28 UN-2A	1.135 (28.8)	.938 (23.8)	.788 (20.0)	.662 (16.8)	.810 (20.6)	.801 (20.3) .796 (20.2)	.822 (20.9)
12	.8750-28 UN-2A	1.190 (30.2)	1.000 (25.4)	.843 (21.4)	.703 (17.9)	.850 (21.6)	.855 (21.7) .851 (21.6)	.885 (22.5)

MIGHTY MOUSE TO ALPHALINK FLEX JUMPERS

Rear-panel-mount environmental push-pull connector to AlphaLink SL flex jumper



804-110

07 - JAM NUT MOUNT I/O RECEPTACLE

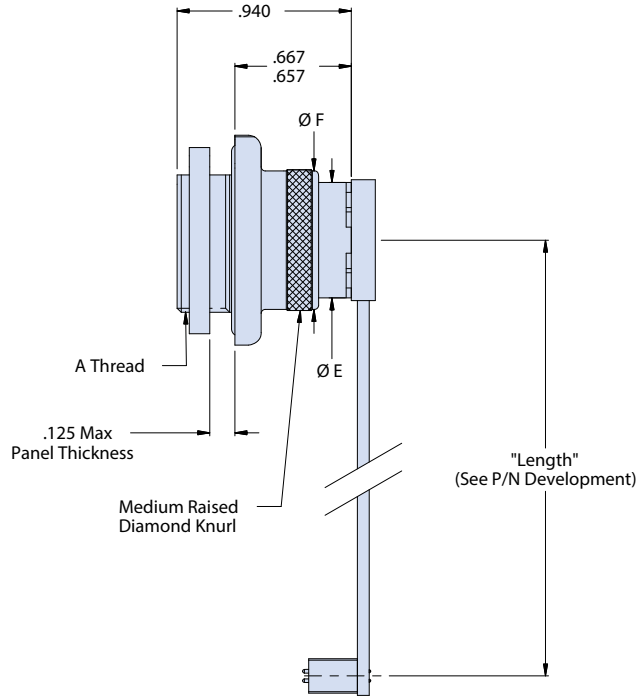
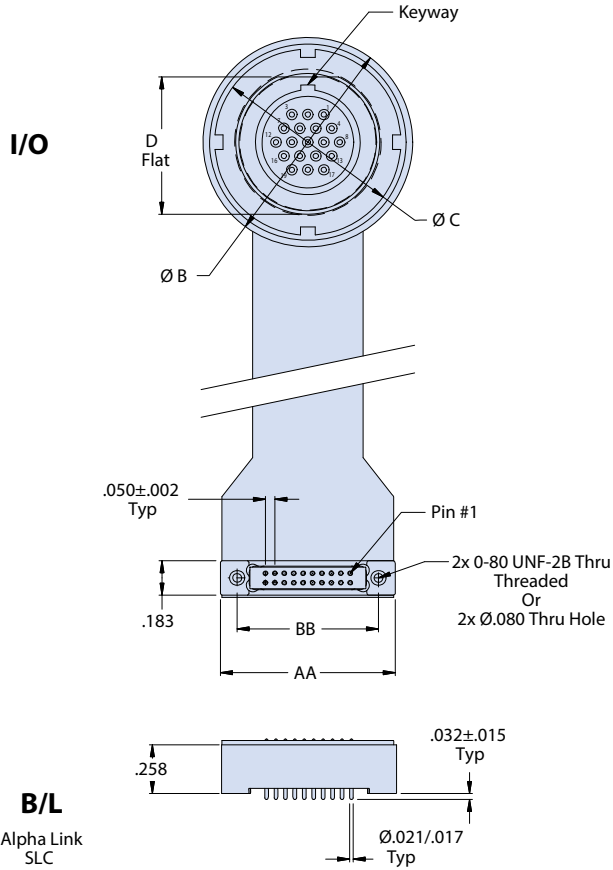

Tag/bag Label

(Part Number)
 (Job Number)
 Glenair 06324
 1 Each D/C (YYWW)

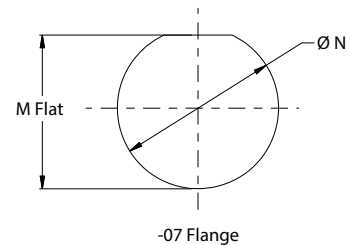

Recommended Panel Cutout

(See Table VI)

