

MOLLE Clip

Installation Instructions:

STAR-PAN VI

808-250 (THS 6-port)

808-037 (rev. 1-5)

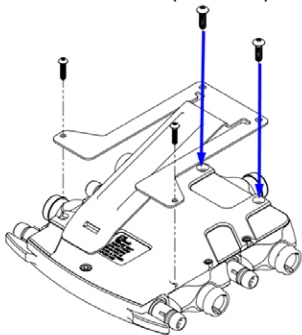

Position the MOLLE clip so the two larger screws are at the top of the hub.

Remove and replace the two large screws at the top of the hub using the following:

Torque Value - 64 ± 8 IN-OZ

Driver Size - 1/16" HEX

MOLLE clip installation
808-250 / 808-037

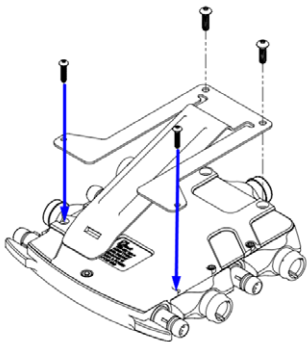

Remove and replace the two smaller screws second from the bottom using the following:

Torque Value - 32 ± 8 IN-OZ

Driver Size - .050" HEX

Do not remove the remaining four screws in the middle portion of the hub, or the bottommost screw.