

A

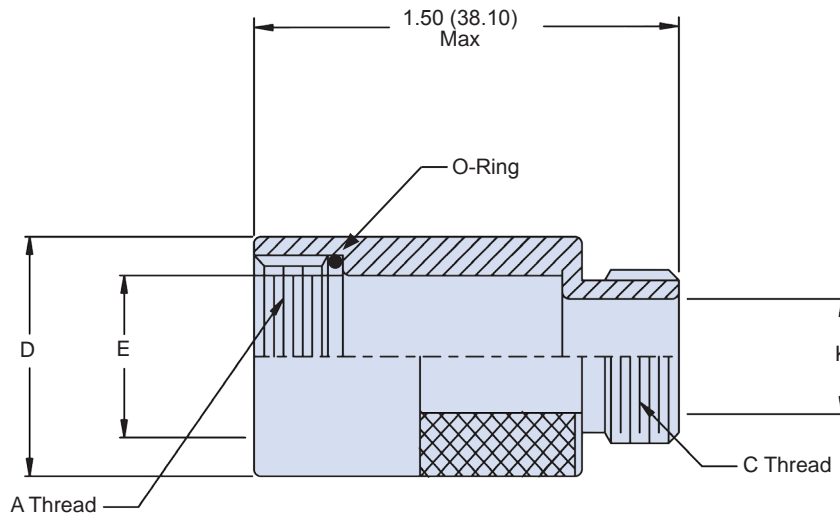
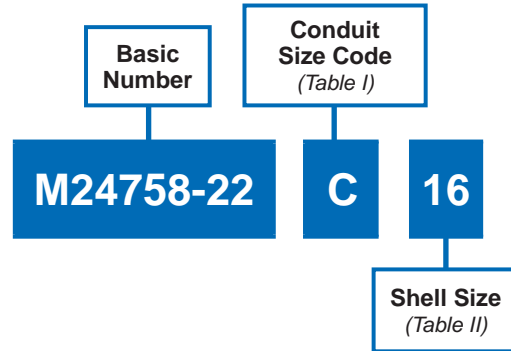

APPLICATION NOTES

1. Assembly identified with manufacturer's code identification number (Glenair, part number and classification code 490).
2. The M24758-22 adapter couples Glenair series 22 connectors to M24758-2, M24758-3 or M24758-4 series fittings.
3. See Glenair Circular Connector Accessories catalog for recommended torque values.
4. Material / Finish:
Adapter, coupling nut - 316 / electroless nickel, matte finish.
O-ring - silicone rubber.
5. Metric dimensions (mm) are indicated in parentheses.

MIL-PRF-24758-22
For Glenair 22 Series Adapters



MIL-PRF
24758A

A

TABLE I

CONDUIT SIZE CODE	C CLASS - 2A THREAD	K DIA MIN
A	.438-28 UNEF	.245 (6.22)
B	.688-24 UNEF	.495 (12.57)
C	.938-20 UNEF	.745 (18.92)
D	1.250-18 UNEF	.995 (25.27)
E	1.563-18 UNEF	1.245 (31.62)
F	1.875-16 UN	1.495 (37.97)
G	2.375-16 UN	1.995 (50.67)
H	2.875-16 UN	2.495 (63.37)
J	.563-24 UNEF	.370 (9.40)
K	.813-20 UNEF	.620 (15.75)
L	3.375-16 UN	2.995 (76.07)

TABLE II

CONN SHELL SIZE	A CLASS - 2B THREAD	D DIA ± .02 (0.5)	E DIA REF
10	.625-24 UNEF	.750 (19.05)	.430 (10.92)
12	.750-20 UNEF	.875 (22.23)	.540 (13.72)
14	.875-20 UNEF	1.000 (25.40)	.660 (16.76)
16	1.000-20 UNEF	1.125 (28.58)	.790 (20.07)
18	1.125-16 UN	1.250 (31.75)	.880 (22.35)
20	1.250-16 UN	1.375 (34.93)	1.000 (25.40)
22	1.375-16 UN	1.500 (38.10)	1.130 (28.70)
24	1.500-16 UN	1.625 (41.28)	1.250 (31.75)