

ITS 31030 A ZL and ITS 31030 R ZL
ITS 41030 A ZL and ITS 41030 R ZL
Rear Panel Mount Square Flange Receptacle Assembly
with BAND-IT Backshell

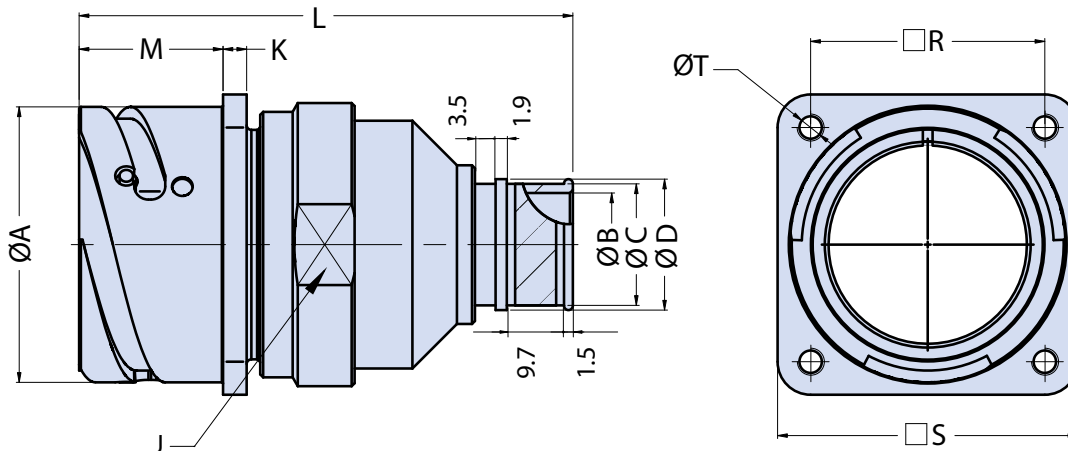
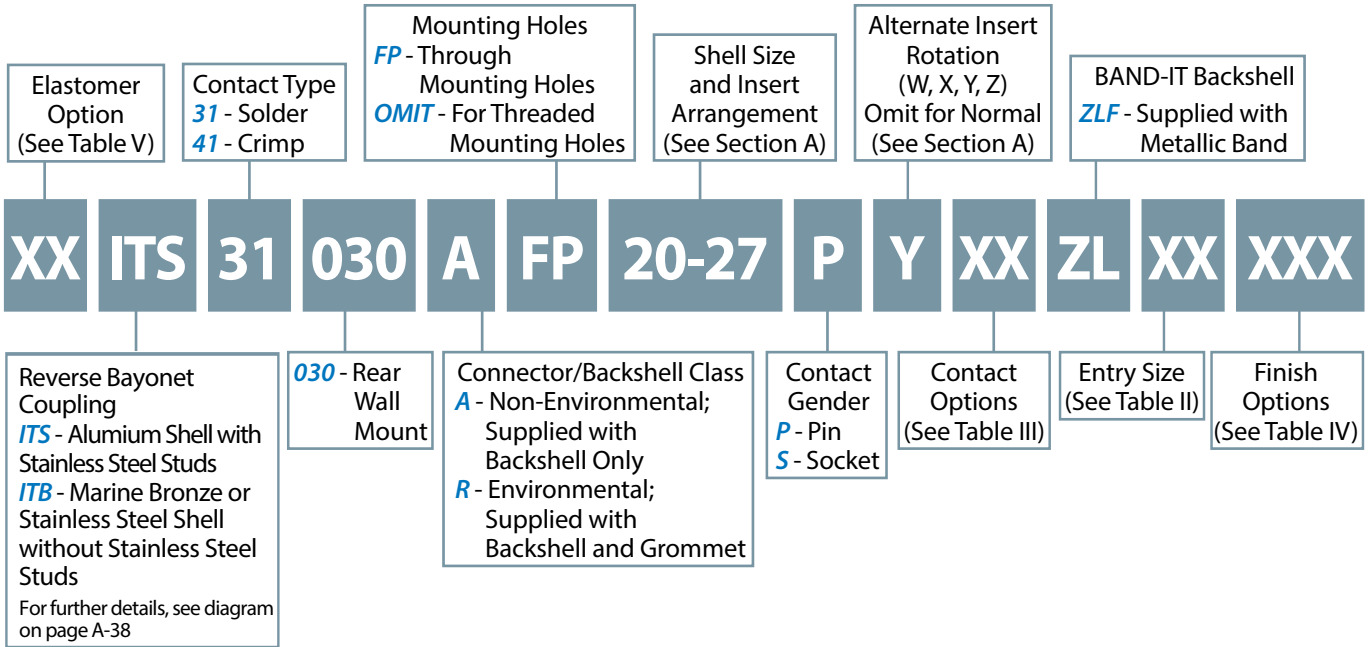

Application Notes

1. Rear panel mount square flange receptacle with backshell for attachment of BAND-IT. Threaded mounting holes. Optional non-threaded mounting holes available.
2. Connector/Backshell Class "A" (non-environmental)—Not supplied with wire sealing grommet; Class "R" (environmental)—Supplied with grommet.
3. Standard materials configuration consists of aluminum alloy. For platings, see TABLE IV finish options.
4. Standard contact material consists of copper alloy with silver plating or gold plating.

ITS 31030 A ZL and ITS 31030 R ZL
ITS 41030 A ZL and ITS 41030 R ZL
Rear Panel Mount Square Flange Receptacle Assembly
with BAND-IT Backshell



TABLE I: DIMENSIONS

Size	L Max.	M +0.2 -0	ØA +0.2 -0.1	J Key	K ±0.2	R ±0.2	S ±0.2	T Thread ^b	Entry Size ^a
10 SL	74.0	18.4	18.2	20	2.8	18.25	25.4	M4	01÷06
14 S	74.0	18.4	24.5	23	3.2	23.00	30.4	M4	03÷08
16 S	74.0	18.4	27.2	26	3.2	24.60	32.5	M4	05÷10
16	81.0	23.2	27.2	26	3.2	24.60	32.5	M4	05÷10
18	90.0	23.2	30.7	28	4.0	27.00	35.0	M4	07÷12
20	97.5	23.2	34.0	32	4.0	29.40	38.0	M4	09÷14
22	101.0	23.2	37.3	36	4.0	31.75	41.0	M4	11÷16
24	101.0	23.2	40.9	39	4.0	34.90	44.5	M4	12÷17
28	108.5	24.2	46.7	46	4.0	39.70	50.9	M5	13÷19
32	113.5	24.2	53.4	52	4.0	44.50	57.0	M5	17÷22
36	113.5	24.2	59.6	58	4.0	49.20	63.5	M5	19÷23
40	118.5	24.2	65.5	65	4.0	55.55	69.9	M5	21÷24

(a) For further entry size, please contact the factory. (b) For through mounting holes refer to page B-3.

TABLE II: ENTRY SIZE TABLE

Entry Size	ØB	ØC	ØD
01	3.2	6.4	7.9
02	4.8	7.9	9.5
03	6.4	9.5	11.1
04	7.9	11.1	12.7
05	9.5	12.7	14.3
06	11.1	14.3	15.8
07	12.7	15.9	17.4
08	14.3	17.5	19.1
09	15.9	19.1	20.6
10	17.5	20.6	22.2
11	19.1	22.2	23.8
12	20.6	23.8	25.4
13	22.2	25.4	27.0
14	23.8	27.0	28.5
15	25.4	28.6	30.1
16	27.0	30.2	31.8
17	28.6	31.8	33.3
18	31.8	34.9	36.5
19	34.9	38.1	39.7
20	38.1	41.3	42.8
21	41.3	44.5	46.0
22	44.5	47.6	49.2
23	47.6	50.8	52.4
24	50.8	54.0	55.5

TABLE III: MODIFICATION CODES

CONTACT OPTIONS	
Sym	Description
B0	Connector without Contacts**
B1	Connector with Gold Plated Contacts
Omit for standard version (Silver plated)	

TABLE IV: MODIFICATION CODES

STANDARD MATERIAL AND FINISH (*)		
Sym	Description	RoHS
	Omit for Aluminum/ Cadmium Olive Drab	
F7	Aluminum/ Black Zinc Nickel	✓
F11	Aluminum/ Electroless Nickel	✓
MB	Marine Bronze/ Unplated	✓
FK	Stainless Steel/ Passivate	✓

TABLE V

ELASTOMER OPTIONS	
Sym	Description
	Omit for Polychloroprene Elastomer
FR	Fire Resistant Elastomer
S	Silicone Elastomer

(*) For further options, please contact the factory.

(**) Crimp Contacts Only