

ITS 3100 F and ITS 4100 F

Front Panel Mount Square Flange Receptacle Assembly with Class A IT3057 Cable Clamp and Polychloroprene Bushing

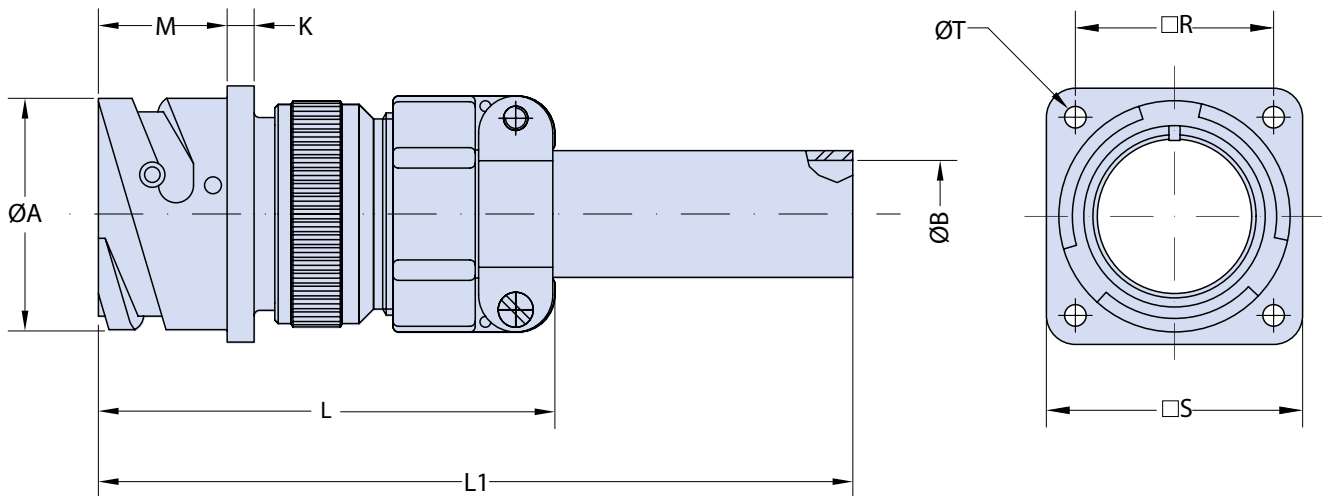
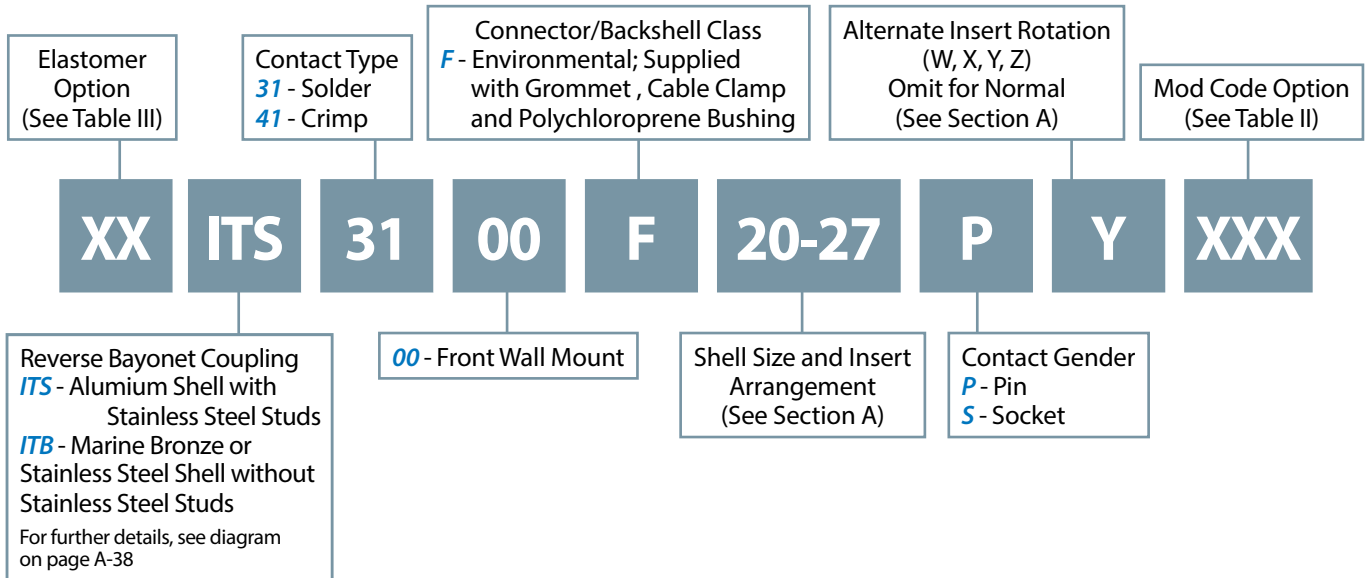

Application Notes

1. Front panel mount square flange receptacle assembly with an insulating grommet, environmental backshell, class A IT3057 cable clamp for use with individual wires and polychloroprene bushing. Through mounting holes.
2. Environmental class "F". Wire sealing grommet supplied.
3. Standard materials configuration consists of aluminum alloy. For platings, see TABLE II finish options.
4. Standard contact material consists of copper alloy with silver plating or gold plating.

**ITS 3100 F and ITS 4100 F
Front Panel Mount Square Flange Receptacle Assembly
with Class A IT3057 Cable Clamp and Polychloroprene Bushing**



TABLE I: DIMENSIONS

Shell Size	ØA +0.2 -0.1	ØB ±0.1	K ±0.2	L Max.	L1 Max.	M +0.4 -0	R ±0.2	S ±0.2	ØT +0.1 -0
10 SL	18.2	5.58	2.8	56.0	114.0	14.2	18.25	25.4	3.2
14 S	24.5	7.92	3.2	60.0	114.0	14.2	23.00	30.4	3.2
16 S	27.2	11.09	3.2	61.5	114.0	14.2	24.60	32.5	3.2
16	27.2	11.09	3.2	72.0	120.5	19.0	24.60	32.5	3.2
18	30.7	14.27	4.0	73.0	120.5	19.0	27.00	35.0	3.2
20	34.0	15.87	4.0	73.0	120.5	19.0	29.40	38.0	3.2
22	37.3	15.87	4.0	73.5	120.5	19.0	31.75	41.0	3.2
24	40.9	19.05	4.0	77.0	120.5	20.6	34.90	44.5	3.7
28	46.7	19.05	4.0	83.0	120.5	20.6	39.70	50.9	3.7
32	53.4	23.79	4.0	88.0	122.5	22.2	44.50	57.0	4.3
36	59.6	31.75	4.0	94.5	124.5	22.2	49.20	63.5	4.3
40	65.5	34.92	4.0	108.5	124.5	22.2	55.55	69.9	4.3

B

TABLE II: MODIFICATION CODES

CONTACT OPTIONS		
Sym	Description	
B0	Connector without Contacts**	
B1	Connector with Gold Plated Contacts	
Omit for standard version (Silver plated)		
STANDARD MATERIAL AND FINISH (*)		
Sym	Description	RoHS
	Omit for Aluminum/ Cadmium Olive Drab	
F6	Aluminum/ Black Electrodeposited Paint	✓
F7	Aluminum/ Black Zinc Nickel	✓
F11	Aluminum/ Electroless Nickel	✓

TABLE III

ELASTOMER OPTIONS	
Sym	Description
	Omit for Polychloroprene Elastomer
FR	Fire Resistant Elastomer
S	Silicone Elastomer

(*) For further options, please contact the factory.

(**) Crimp Contacts Only