

# Rack-and-panel plug

253-020-09

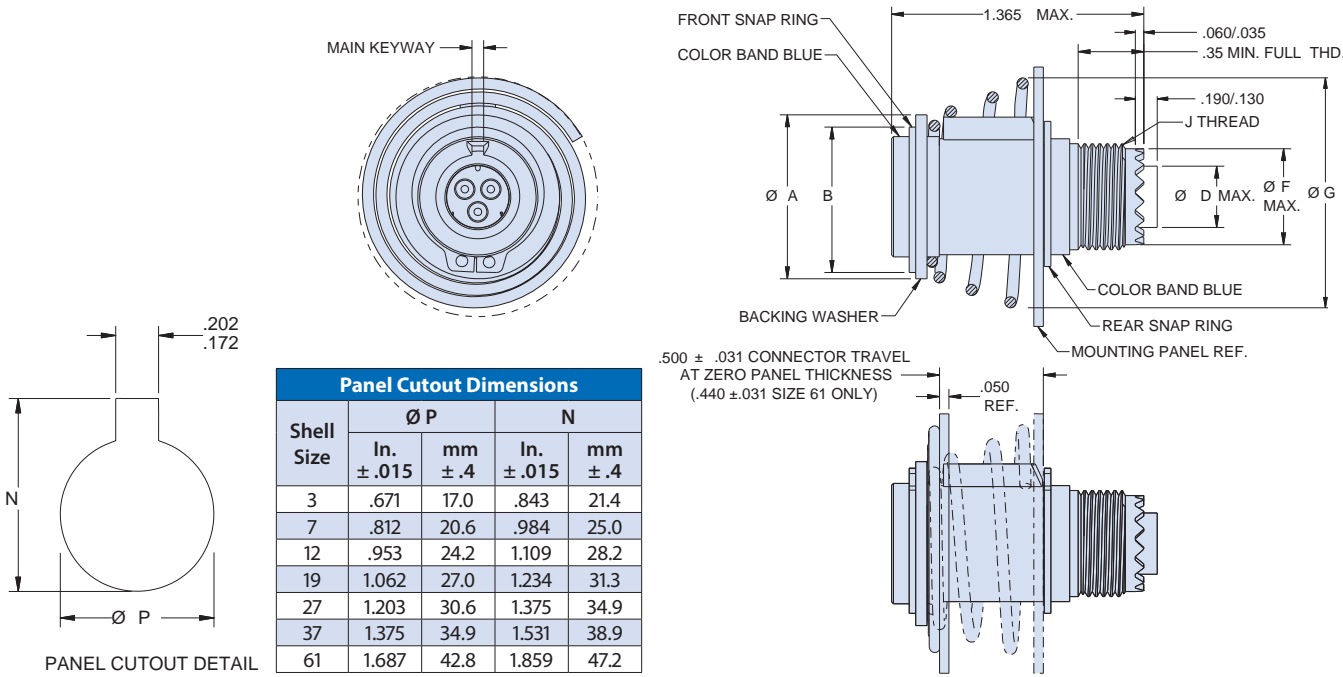

How To Order							
<b>Sample Part Number</b>	253-020	-	09	ME	19-7	P	N
<b>Basic Part Number</b>	AS81703 Series 3 type connector						
<b>Rear Option</b>	-- = Accessory threads    B = Band porch (consult factory)						
<b>Connector Style</b>	09 = Rack & panel plug                      AS34461 type (MS3446)						
<b>Material / Finish</b>	C = Al Alloy/Black Anodize    ME = Al Alloy/Electroless Nickel    MT = Al Alloy/Nickel-PTFE NF = Al Alloy/Cad O.D. Over Electroless Nickel    ZR = Al Alloy/Zinc-Nickel Black						
<b>Shell Size / Insert Arrangement</b>	See Table II pg. 2, diagrams on pgs. 4-5						
<b>Contact Styles</b>	P = Pin insert    S = Socket insert    A = Pin insert less contacts    B = Socket insert less contacts						
<b>Insert Clocking Positions</b>	N, W, X, Y, B, C (See Table III pg. 2)						



-09 Rack-and-Panel Plug Dimensions												
Shell Size	Ø A		Ø B Max.		Ø D Max.		Ø F Max.		Ø G Max.		J Thd.	Spring force when mated (lbs-in.)
	In.	mm	In.	mm	In.	mm	In.	mm	In.	mm		
3	.891 .869	22.6 22.1	.800	20.3	.351	8.9	.509	12.9	1.225	31.1	9/16-24 UNEF-2A	16 - 20
7	1.172 1.150	29.8 29.2	.990	25.1	.531	13.5	.687	17.4	1.356	34.4	3/4-20 UNEF-2A	16 - 20
12	1.263 1.241	32.1 31.5	1.190	30.2	.665	16.9	.812	20.6	1.575	40.0	7/8-20 UNEF-2A	30 - 35
19	1.391 1.369	35.3 34.8	1.320	33.5	.790	20.1	.937	23.8	1.715	43.6	1-20 UNEF-2A	40 - 50
27	1.529 1.507	38.8 38.3	1.475	37.5	.869	22.1	.992	25.2	1.860	47.2	1 1/16-18 UNEF-2A	43 - 50
37	1.816 1.794	46.1 45.6	1.655	42.0	.994	25.2	1.117	28.4	2.120	53.8	1 3/16-18 UNEF-2A	45 - 53
61	2.150 2.118	54.6 53.8	2.025	51.4	1.280	32.5	1.427	36.2	2.850	72.4	1 1/2-18 UNEF-2A	75 - 80