

# QwikConnect

GLENAIR ■ OCTOBER 2010 ■ VOLUME 14 ■ NUMBER 4



Electronica  
2010

*New Product  
Launch Extravaganza*

**G**lenair®



# Electronica 2010, Munich, Germany *New Product Launch Extravaganza*

Willkommen! Glenair has a long history of interconnect system product innovation. We designed and built the Golden Umbilical Cable used by Commander Ed White in the first ever space walk. We solved the mechanical and environmental problems that allowed the F-16 to successfully route its fly-by-wire cabling through the fuel tanks in the aircraft's wings. Our innovative fiber optic termini design fixed the data loss problems in the F-35 Joint Strike Fighter. Our revolutionary composite thermoplastic components are reducing weight and corrosion damage on countless air, land and sea applications. We invented the ultra-miniature Series 80 Mighty Mouse Connector that has become the new, industry-standard replacement for larger MIL-DTL-38999 connectors. The list goes on and on.

New product innovation is a hallmark of our business model at Glenair (see Chris Toomey's *Outlook* column for more details). And at no time in our company's history have we had more innovative development projects underway than at this very moment.

Every two years Glenair participates in the world's largest and most successful electronics trade show, Electronica in Munich, Germany. Over the years we have launched dozens of new products at Electronica, as the venue affords us a unique opportunity to meet with a broad range of customers and industry experts in one place and at one time. This year we have put together our most extensive new product rollout ever. At last count we will be rolling out 15 new product lines or component series at Electronica 2010.

As airplane tickets to Germany can be rather expensive, we decided to bring the flavor and excitement of the event to our readers who can't make it to the show with this special Electronica 2010 New Product Launch Extravaganza issue of *QwikConnect*. We invite you to peruse the many new solutions we will be introducing to the marketplace this year in Munich—all with our patented Glenair service—including in-stock availability on popular part numbers, outstanding technical support, free application engineering, ample manufacturing capacity as well as rapid response on quotes and special orders.

So, grab yourself a Märzen (or an Alkoholfreies Bier if you have to drive) and feast your eyes on these 15 innovative new products from Glenair. We think you'll be impressed with how well these products, like this Oktoberfest barmaid, do their job. And by the way, don't hesitate to contact the factory for a catalog, a sample, or even better, price and delivery.



## WHY CHOOSE GLENAIR?

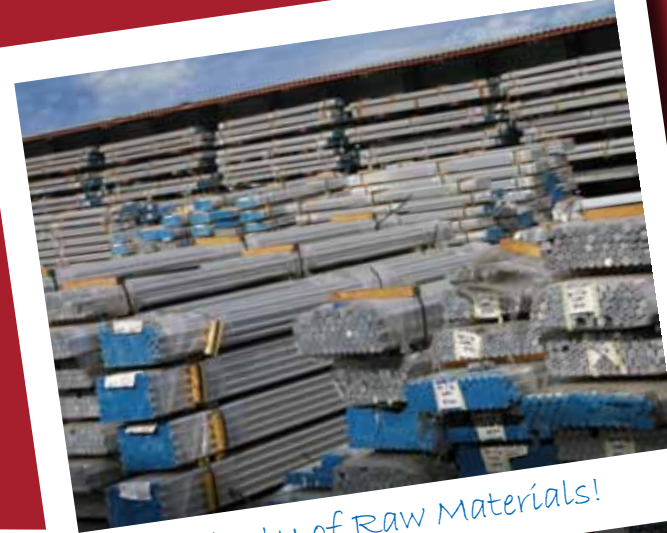

Plenty of Raw Materials!



Outstanding Customer Service!



Abundant Machining Capacity!



In-House Assembly!



Huge "Same-Day" Inventory!





# SAE AS39029 QPL Contacts

## High Performance Qualified M39029 Contacts Now Available with Accelerated Lead Times—and No Minimums!

### Outstanding Product Availability

Glenair brings a new perspective to the supply of Mil-Spec crimp contacts: High Availability! Whether you need a standard duty socket for a MIL-DTL-28840 connector or an extended duty pin for MIL-DTL-38999 Series II we have you covered with products that are always in stock—with no dollar or quantity minimums. In addition to the broadest selection and availability, Glenair also delivers outstanding interconnection compatibility. Glenair SAE-AS39029 contacts are guaranteed to mate properly and perform at the upper limits of application and specification requirements.

### Shielded Contacts and Fiber Optic Termini a Specialty

Glenair shielded high-speed/frequency contacts are specified according to size, cable choice and impedance. The contacts are easily incorporated into standard 8, 12 and 16 size contact cavities, enabling users to interchange high-frequency contacts into a broad range of connector insert arrangements. Special 50 Ohm matched impedance contacts, for example, are available as are various coaxial and/or quadrx contact configurations. High speed matched impedance cables are also supplied by Glenair, complementing our new contact product line capability.



### About SAE AS39029 Crimp Contacts

In a marketplace saturated with specialty interconnection products, the SAE-AS39029 crimp contact is still the “bread and butter” of most standard circular and rectangular connectors. Serving platforms like the D38999, M28840 and countless others, AS39029 crimp contacts deliver reliable power and signal transmission in ruggedized military and commercial applications. The wide range of sizes, termination options and material types enable end users to avoid undesirable compromises in performance and reliability.

Glenair AS39029 contacts are primarily supplied in crimp termination versions. Crimping results in a gas tight connection between the wire and its terminal. Although there are certainly alternatives to crimping, such as ultrasonic welding, resistance welding, insulation displacement technologies and so on, no other available technology delivers the short cycle times, flexibility and low overall cost of crimping—making it the termination technology of choice for most high-performance connector systems.

Crimp connectors are most commonly used to terminate stranded wire. Crimp-on terminals are attached by inserting the stripped end of the wire into the barrel end of the terminal, which is then mechanically deformed (crimped). Military Specification MIL-DTL-22520 provides the aerospace/defense industry with a common set of rugged, reliable hand crimp tools. This specification controls the voltage drop and tensile strength of crimp terminations. Daniels Manufacturing Corporation is the leading manufacturer of these tools. Special crimp tools or pliers are a must, and are supplied by Glenair with appropriate accessory attachments to insure reliable terminations for every wire and contact combination.

The AS39029 product series supplied by Glenair includes all the most popular standard and extended duty pin and socket contacts for use in high-performance circular and rectangular multi-pin connectors. We are also well positioned to supply special-purpose contacts to meet unique application requirements. Below is a selection of the qualified top level slash-sheet part numbers now supplied by Glenair.

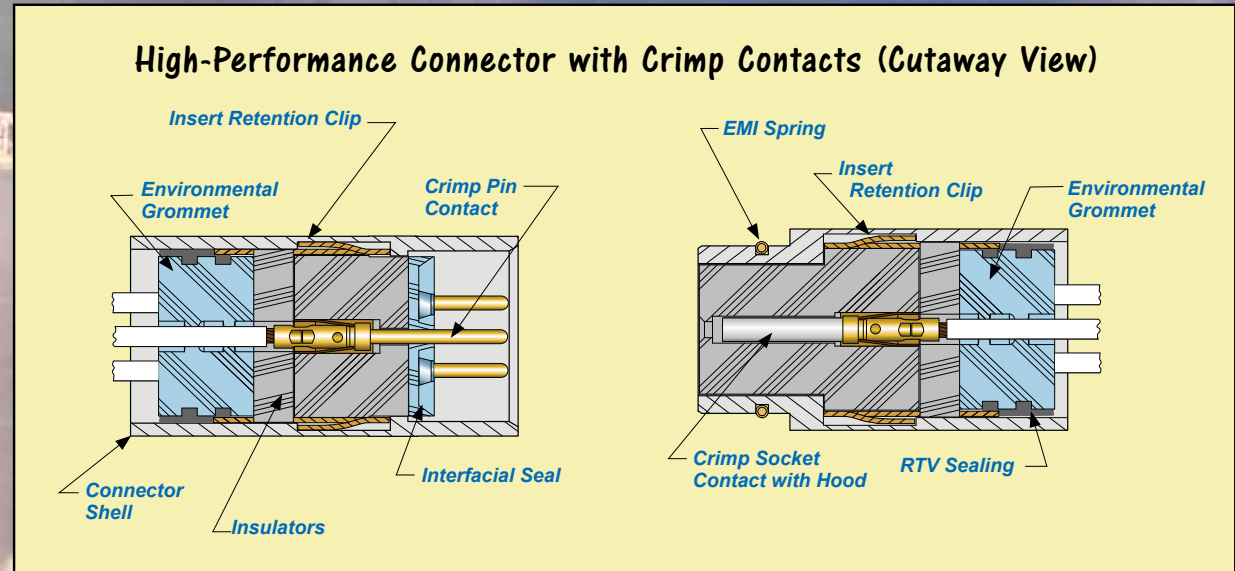

- ◆ Final SAE-AS39029 Qualification Pending on Dozens of Contacts
- ◆ Same Day Inventory on Popular and Hard-to-Find Styles
- ◆ Highest Quality Materials Including Enhanced Durability Plating
- ◆ Fully Intermatable with Equivalent AS39029 QPL Contacts

- ◆ M39029/27
- ◆ M39029/28
- ◆ M39029/56
- ◆ M39029/57
- ◆ M39029/58
- ◆ M39029/59
- ◆ M39029/60
- ◆ M39029/75
- ◆ M39029/76
- ◆ M39029/77
- ◆ M39029/78
- ◆ M39029/83
- ◆ M39029/84
- ◆ M39029/90
- ◆ M39029/91
- ◆ M39029/102
- ◆ M39029/103
- ◆ M39029/106
- ◆ M39029/107
- ◆ M39029/113
- ◆ M39029/114



# Well-Master™ 260 Micro-D

## Glenair Well-Master™ 260—The Micro-D Connector for Serious, High-Temperature Applications



- ◆ 260° continuous operating temperature
- ◆ Angled mounting ears for easy fit in small diameter instruments
- ◆ High reliability TwistPin contact system with special high temperature alloy .050" pitch contact spacing
- ◆ Solder cup, pre-wired or pcb

Standard Micro-D connectors are rated for +125°C. Glenair's MWDM Micro-D can withstand +150°C continuous operating temperature and can be upgraded to +200°C if assembled with special high temperature epoxies. But oil, gas and geothermal wells can subject electronic instruments to temperatures as high as +260°C. The GHTM Series Micro-D meets the need for a high density, high performance connector capable of handling this temperature. The GHTM features contacts made from a special alloy that resists softening when exposed to temperatures up to +260°C (500°F). Rugged passivated stainless steel shells and hardware, high temperature liquid crystal polymer (LCP) insulators and special epoxies allow these connectors to survive the most demanding environments. Unique angled mounting ears allow the Well-Master™ 260 to fit in confined spaces

### GHTM HIGH TEMPERATURE CONTACT ARRANGEMENTS

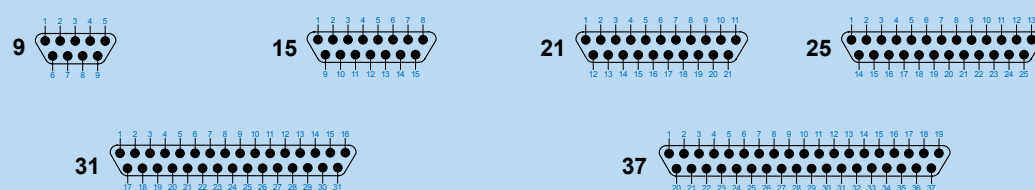

Mating face of pin connector. Socket connector contact numbers are reversed.

### MATERIALS AND FINISHES

Contacts	Proprietary nickel alloy, gold plated
Insulators	Liquid crystal polymer (LCP)
Shell	Stainless steel, passivated
Mounting Hardware	Stainless Steel
Potting Compound	Epoxy
Insulated Wire	Nickel-coated copper, PTFE insulation per M22759/87 (260°C)

### SPECIFICATIONS

Current Rating	3 Amps
Contact Resistance	8 milliohms maximum
Dielectric Withstanding Voltage	600 Vac sea level
Insulation Resistance	5000 megohms minimum
Operating Temperature	-55° C. to +260° C.
Shock	300 g.
Vibration	37 g.

GHTM Well-Master™ 260 Solder Cup

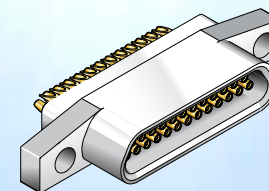

GHTM Well-Master™ 260 Pre-Wired

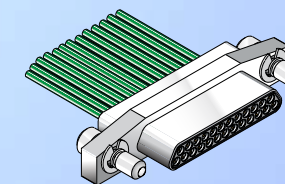

GHTM Well-Master™ 260 Back-to-Back

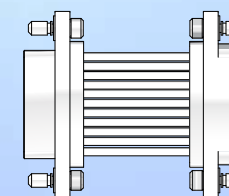

GHTM Well-Master™ 260 Right Angle PCB

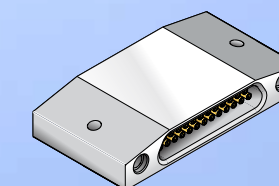



# Series 28 HiPer-D 24308

## Bringing 21<sup>st</sup> Century Technology to the World's Most Popular Connector Interface

### The Extreme Duty D-Sub Connector

Meet the Series 28 HiPer-D. Intermatable and intermountable with standard M24308 type D-Subs, the HiPer-D meets the need for improved performance in hostile environments. Unlike standard M24308 connectors with stamped steel shells, the HiPer-D is machined from aluminum or stainless steel. The dielectric inserts are made with thermoset epoxy for unbeatable resistance to chemicals and are capable of 200°C continuous operating temperature. Aerospace grade fluorosilicone grommets and face seals provide watertight sealing.

### PRODUCT FEATURES

- ◆ Environmental, crimp removable rectangular connector
- ◆ Advanced temperature, vibration and EMC/electrical performance
- ◆ M24308/D-Sub intermatable
- ◆ Fits panel and pcb footprint of M24308/D-Sub products
- ◆ Available in all 11 "standard" insert arrangements

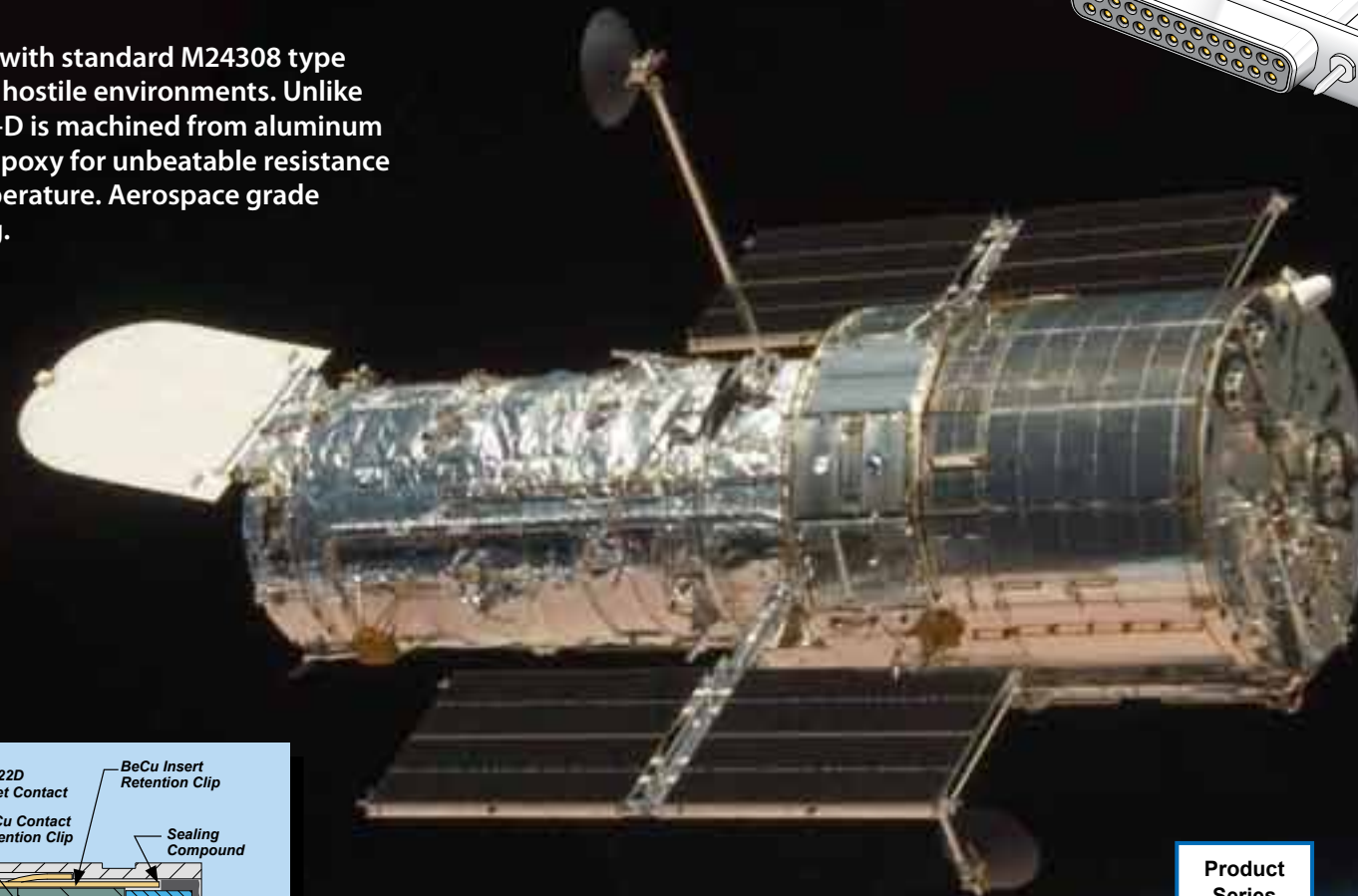
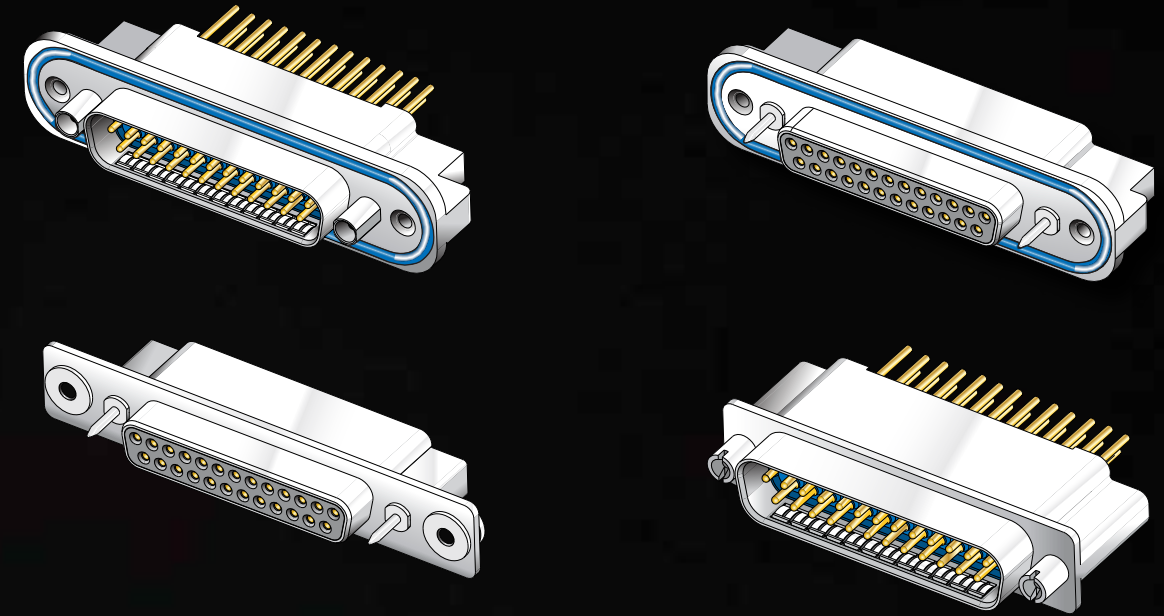

### AVAILABLE CONFIGURATIONS

- ◆ Crimp Termination for Attaching Wire or Cable: Standard Cable, Rear Panel Mount and Float Mount
- ◆ Printed Circuit Board Termination for Rear Panel Mounting: Straight and Right Angle
- ◆ Free-Standing Printed Circuit Board Termination: Straight and Right Angle

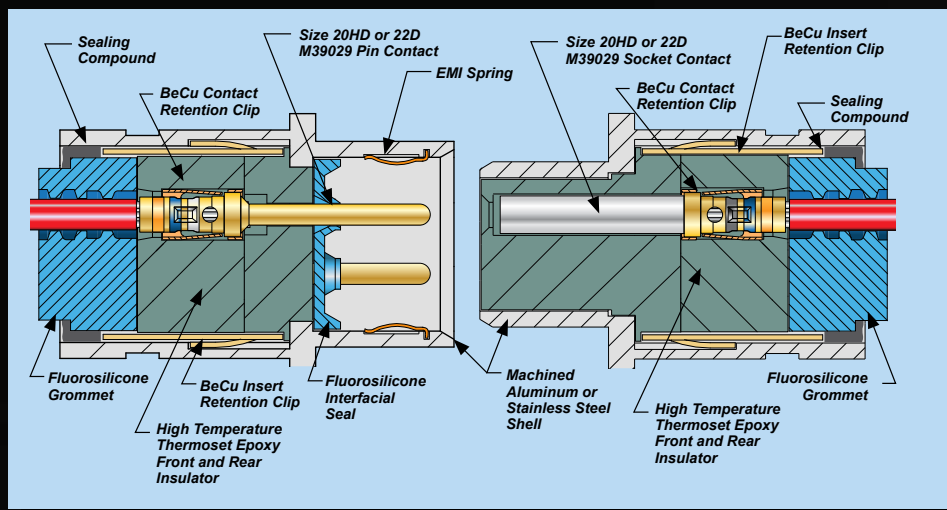

### How To Order

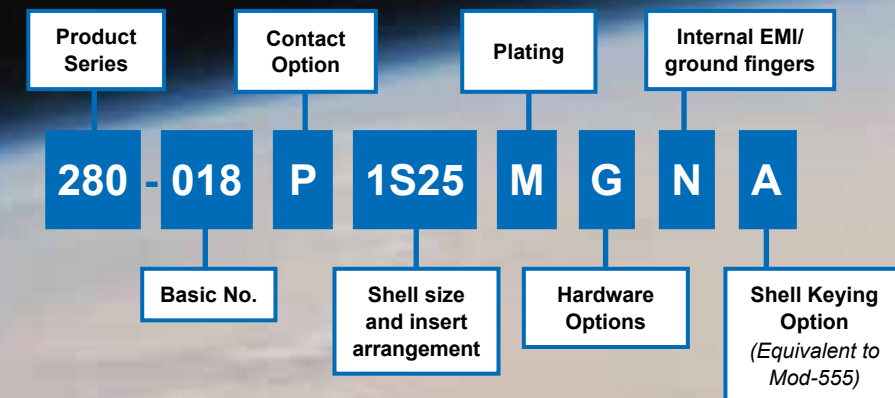



# Mighty Mouse Fiber Optic



Series 801 Plug with 181-057 pin terminus



Series 801 receptacle with 181-075 socket terminus

- ◆ Single Mode and Multi Mode
- ◆ Snap-in, Rear Release
- ◆ Precision Ceramic Ferrules
- ◆ 0.5 dB Typical Attenuation
- ◆ 1 to 22 Channels

## The Perfect Marriage of High Bandwidth Fiber Optics with Ultra-Miniature Packaging

New size #16 fiber optic termini can be used in any standard Mighty Mouse connector. Available for single mode or multi-mode fiber, these termini have low insertion loss and are intended for high-reliability aerospace applications. Series 80 connectors offer substantial reductions in size and weight compared to our D38999 type fiber optic connectors.

### SERIES 80 CONTACT ARRANGEMENTS FOR USE WITH #16 FIBER OPTIC TERMINI

1 #16	2 #16	4 #16	2 #16, 4 #23	5 #16	2 #16, 8 #23	7 #16	12 #16	14 #16	22 #16

See Series 80 Mighty Mouse catalog for connector ordering information. Order connectors less contacts and order fiber optic termini separately. Cavity numbers are mating face view of pin connectors.

The Series 801 9-4 receptacle is less than half the size of our D38999 type fiber optic connector.



Series 801  
6 Grams  
(less contacts)

D38999 Series III  
27 Grams  
(less contacts)

### Size #16 Fiber Optic Termini

Size #16 fiber optic termini are compatible with all Series 80 Mighty Mouse connectors with size #16 cavities. These snap-in, rear-release termini feature precision ceramic ferrules and sleeves for accurate fiber alignment. Typical insertion loss 0.5 dB. Fits 50/125 and 62.5/125 multi mode and 9/125 single mode fiber. Stainless steel bodies and springs.

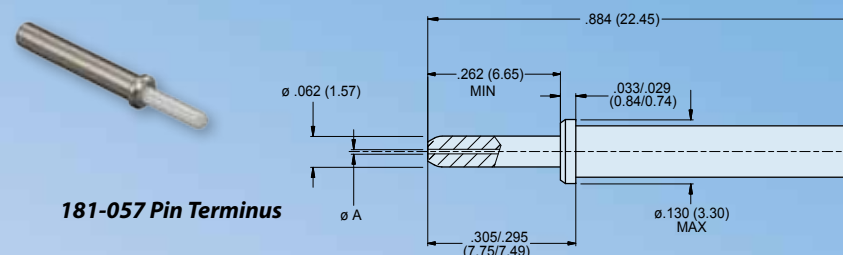

181-057 Pin Terminus

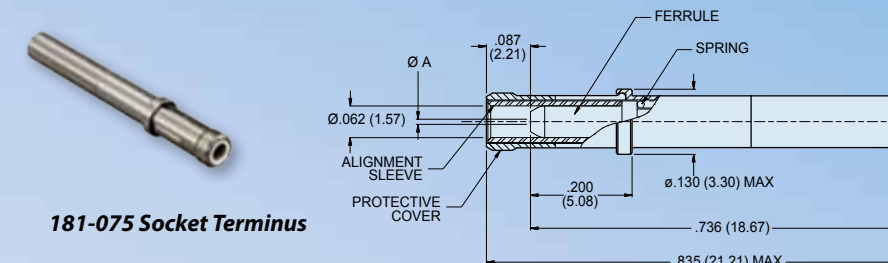

181-075 Socket Terminus

Termini Type	Optical Fiber Type	Part Number	A Ferrule I.D.
Pin	Multi Mode	181-057-126	126.0 microns
Pin	Single Mode	181-057-125	125.5 microns
Socket	Multi Mode	181-075-126	126.0 microns
Socket	Single Mode	181-075-125	125.5 microns

### Materials and Finishes

Terminus Body: stainless steel, passivated  
 Ferrule: zirconia ceramic  
 Protective cover: copper alloy, nickel plated  
 Spring: stainless steel, passivated  
 Alignment sleeve: zirconia ceramic

### Specifications

Insertion Loss: 0.5 dB typical  
 Operating Temperature: -65° to + 200° C  
 Durability: 500 cycles

### Insertion/extraction Tool

Standard size #16 plastic tool  
 Glenair Part Number 809-131  
 Military Part Number M81969/14-03

### Termination Procedure

The assembly process is similar to industry-standard procedures for MIL-PRF-29504 termini.

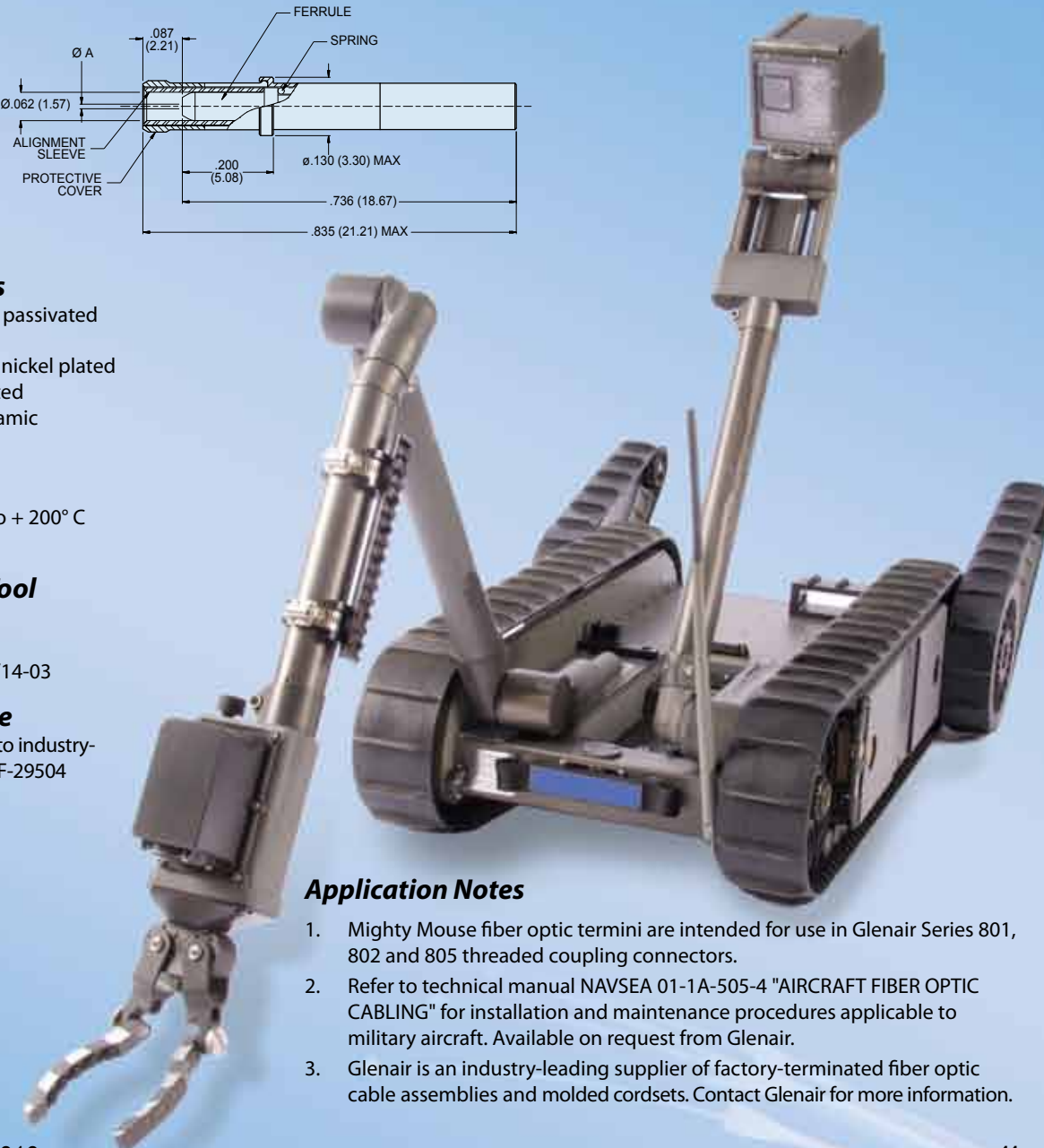

### Application Notes

1. Mighty Mouse fiber optic termini are intended for use in Glenair Series 801, 802 and 805 threaded coupling connectors.
2. Refer to technical manual NAVSEA 01-1A-505-4 "AIRCRAFT FIBER OPTIC CABLING" for installation and maintenance procedures applicable to military aircraft. Available on request from Glenair.
3. Glenair is an industry-leading supplier of factory-terminated fiber optic cable assemblies and molded cordsets. Contact Glenair for more information.



# “Hat Trick Series” Conduit

## The Big-Scoring, Three-In-One Conduit Adapter for High Performance Helical Tubing

The New Glenair Series 74 “Hat Trick” conduit system is designed for use with High-performance, helical PTFE or PEEK conduit. Cleverly designed fittings provide three key functions—conduit attachment, shield termination and boot attachment in an easy-to-use compact fitting. The user-installable fitting is equipped with a threaded inner shell, banding porch and shrink boot groove as well as a self-locking coupling nut. Conduit threads directly into shell cavity for rapid attachment. The system is environmental to IP66 when equipped with a boot. For more information, please reference part numbers 713-355 (Connector adapter), 713-359 (Bulkhead feed-through), and 713-358 (Conduit-to-Conduit Transition Adapter).

### PRODUCT FEATURES

- ◆ Aluminum Alloy with Complete Range of Plating Options
- ◆ Environmentally Sealed
- ◆ Self-Locking Coupling Nuts
- ◆ Connector, Panel and Conduit-to-Conduit Adapters
- ◆ Straight, 45° and 90° Low-Profile Configurations

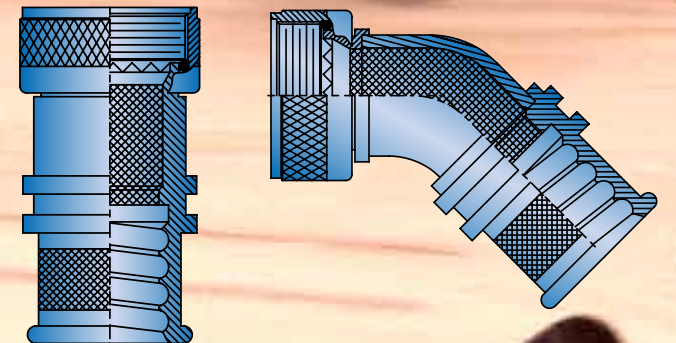
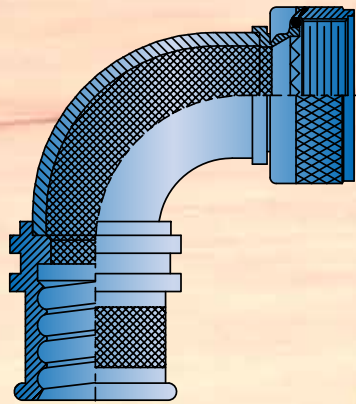



# Heat Shrinkable Transitions

## Another "No Gaps" Solution: Glenair Series 77 "Full Nelson" Shrink Boot Line Expands with "Y" and "T" Transitions

### Same Great Materials, Availability and Service—New "Y"s and "T"s

Shrink boots provide mechanical and environmental protection to connector-to-cable transitions. Specially formulated polymers are injection-molded, then heated and expanded. The shape-memory property of the material allows it to return to its original shape when heated with a hot airgun. Optional adhesive coatings on the inside of the boot provide a watertight, high-strength bond to the cable jacket and the connector or adapter. Glenair is happy to announce the ongoing expansion of our Series 77 Full-Nelson line to include "Y" and "T" transitions. The products are fully tooled in low profile and wide body versions and available in three high-temperature materials, with and without adhesives. Call the factory for price and delivery today!

### Material Selection Guide

Property	Type 1 High Performance Semi-Rigid Elastomer	Type 2 Zero Halogen Semi-Flexible Polyolefin	Type 3 General Purpose Flexible Polyolefin
Continuous Operating Temperature	-75° to +150°C	-30° to +125°C	-55° to +135°C
Resistance to Fuels, Oils, and Fluids	Excellent	Very Good	Good
Low Toxicity, Zero Halogen	No	Yes	No
Specifications	VG 95343 Part 6 BSG 198-5-DE EN62329-102 AS5258 Type H	VG 95343 Part 29 BSG 198-5-DF EN62329-101 AS5258 Type G NAVSEA 5617649	MIL-I-81765/1 Type II AS5258 Type B

### Low Profile "Y" Cable Transition

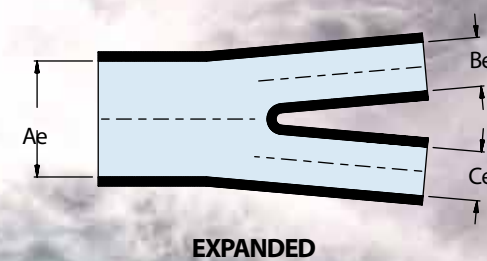

SIZES  
05-08

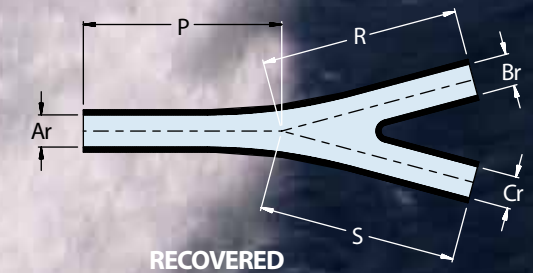

### Wide Body "T" Cable Transition - Dimensions

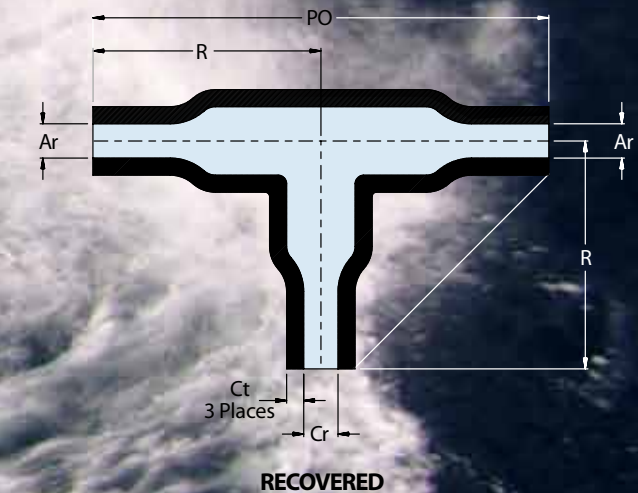
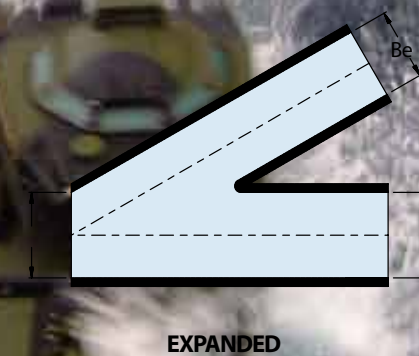

**Transition Profile**  
 770-009Y - Low Profile "Y" Transition  
 770-010Y - Wide Body "Y" Transition  
 770-011T - Wide Body "T" Transition  
 770-012T - Low Profile "T" Transition

Transition Size	Transition Size			
	770-009Y	770-010Y	770-011T	770-012T
05	05	01	01	
06	06	02	02	
07	07	03	03	
08	08	04	04	
16				
25				

**770-009Y** **1** **05** **W1**

**Transition Material**  
 1 - Elastomeric, semi-rigid, 150°C compound  
 2 - Low smoke, zero halogen compound  
 3 - Flexible polyolefin compound

**Adhesive Options**  
 W1 - High temperature hot melt adhesive  
 W2 - Standard hot melt adhesive  
 R - High performance epoxy adhesive



# Low Profile Micro-D

## Low Profile Micro-D's are the New Space-Saving Alternative to Standard MWDM Connectors

Low profile MLDM metal shell and MWD plastic shell connectors are intended for high reliability board-to-wire I/O and wire-to-wire applications. Gold-plated TwistPin contacts provide excellent performance when subjected to high levels of shock and vibration. Plastic and metal versions are intermateable. Flange height is reduced by 33% compared to MWDM standard Micro-D connectors

### PRODUCT FEATURES

- ◆ Metal Shell or One-Piece Plastic
- ◆ High Reliability TwistPin Contact System
- ◆ .050" Pitch Contact Spacing
- ◆ Solder Cup, Pre-Wired or PCB Headers
- ◆ 3 Amps, +150c, 600 Vac

### SIZE COMPARISON

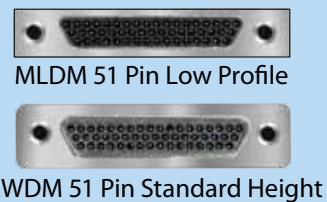

### LOW PROFILE MLDM AND MWD CONTACT ARRANGEMENTS (PIN FACE)

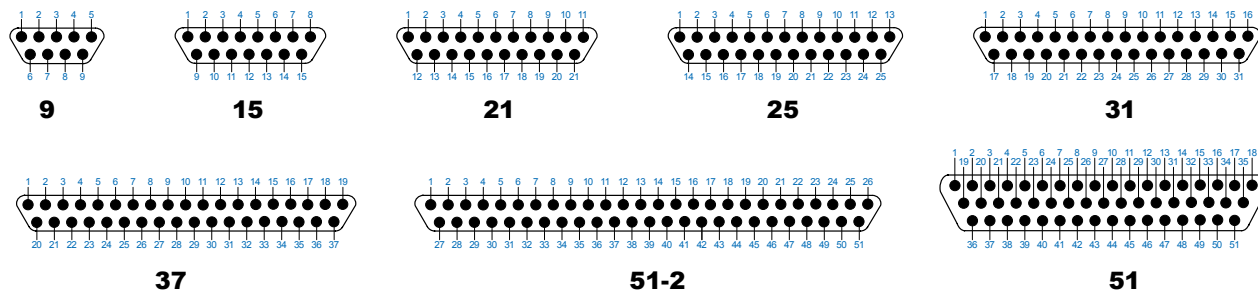

### MATERIALS AND FINISHES

Contacts	Copper alloy, 50 μ inch gold over nickel
Insulators	Liquid crystal polymer (LCP)
Shell	Aluminum alloy
Mounting Hardware	Stainless Steel
Potting Compound	Epoxy
Insulated Wire	Per MIL-W-22759/11 and /33
Solid Wire, PC Tails	Per A-A-59551, gold plated or tinned

### SPECIFICATIONS

Current Rating	3 Amps
Contact Resistance	8 milliohms maximum
Dielectric Withstanding Voltage	600 Vac sea level
Insulation Resistance	5000 megohms minimum
Operating Temperature	-55° C. to +150° C.
Shock	300 g.
Vibration	37 g.



### MLDM Metal Shell, Solder Cup

Solder cup contacts accept #24 AWG solid or stranded wire. Available in 9 to 51 positions. High performance M83513 TwistPin contact system. Contacts are factory-installed, non-removable and are encapsulated with epoxy. Gold-plated PC tails. 3 Amp, 600 Vac, -55C to +150C.



### MLDM Metal Shell, Pre-Wired

Solder cup contacts or pre-wired to #24 to #30 stranded wire or uninsulated solid wire. Available in 9 to 51 positions. High performance M83513 TwistPin contact system. Contacts are factory-installed, non-removable and are encapsulated with epoxy. 3 Amp, 600 Vac, -55C to +150C.



### MLDM Metal Shell, Right Angle PCB

Available in 9 to 51 positions. High performance M83513 TwistPin contact system. Contacts are factory-installed, non-removable and are encapsulated with epoxy. PCB terminal spacing is .100" x .100" for easy board fabrication. 3 Amp, 600 Vac, -55C to +150C.



### MWD All-Plastic, Solder Cup

These connectors are available with nine through 51 contacts. Featuring the same TwistPin contact system as the MLDM metal shell connector, the MWD is smaller and more economical. Gold-plated solder cups accept #24 – #30 AWG wire. 3 Amp, 600 Vac, -55C to +150C.

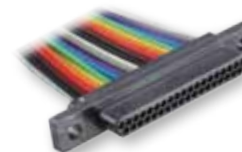

### MWD All-Plastic, Pre-Wired

These crimp-terminated pre-wired assemblies offer an alternative to the time-consuming job of soldering wires. Connectors are available with insulated, stranded mil spec wire or with uninsulated single strand wire. Back-to-back cables assemblies are also available. #24 – #30 AWG wire size. 3 Amp, 600 Vac, -55C to +150C.

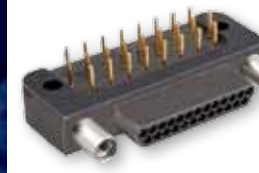

### MWD All-Plastic, Right Angle PCB

Available in 9 to 51 positions. High performance M83513 TwistPin contact system. Contacts are factory-installed, non-removable and are encapsulated with epoxy. Gold-plated PC tails. PCB terminal spacing is .100" x .100" for easy board fabrication. 3 Amp, 600 Vac, -55C to +150C.



**THE TEN MOST IMPORTANT FACTS ABOUT Beer KNOWN TO MAN**



**B**eer lovers have a dear departed hero in one Duke Wilhelm IV of Bavaria who in 1516 enacted the world's first ever consumer protection law. The beer purity law, called *Reinheitsgebot* in German, limited the ingredients of beer to barley, hops and water. Today, most German brewers stretch the original recipe to include a fourth ingredient, yeast. The *Reinheitsgebot* was important at the time as beer was a major source of nutrition for Germans, and in fact in Bayern (Bavaria) beer is

still officially considered a staple food. Anyway, our boss challenged us, in the spirit of this special Electronica issue, to honor the Bavarian Duke with a centerfold highlighting the most extraordinary beer facts we could find. We are of course happy to oblige, but feel we need to first take pause to enjoy another entirely gratuitous picture from Oktoberfest:



With that important task behind us, we can apply ourselves in earnest to our presentation of **The Ten Most Important Facts About Beer Known to Man**, starting with:



**#10 Love of Beer Drove Cavemen to Settle Down and Raise Families:**

The pursuit of beer changed the course of humanity forever in 5000 BC when Neolithic people abandoned their wandering ways in favor of a more sedentary lifestyle. Turns out the desire to stick around in one place long enough to grow grain for brewing beer was the greatest single factor in the civilization of early man and eventually led to the invention of the personal computer, the hair-care products industry and countless other treasures of modern life.

**#9 Brewing Process Reveals Evolutionary Link Between Man, Monkeys, and Beer:**

Before thermometers were invented, brewers would dip their thumbs into the brew mix to determine the right temperature for adding yeast. Too cold and the yeast wouldn't grow; too hot and the yeast would die. This ancient and clever use of an opposable thumb to perform a job (just like monkeys!) gave birth to the popular expression "rule of thumb," which, of course, later gave rise to the saying, "thumb like it hot and thumb like it cold".



**#8 Origin of Expression, "Honey, Would You Get Me Another Beer:"**

In Babylon over 4000 years ago, it was customary for the bride's father to supply his new son-in-law with all the mead he could drink for a month. As mead is a honey beer and their calendar was lunar-based, this period was called the "honey month" – or what we know today as the 'honeymoon'. Speaking of marriage and drinking, a churlish woman once said to Winston Churchill, "Sir, if you were my husband, I would poison your drink." Churchill famously replied, "Madam, if you were my wife, I would drink it."



**#7 Death By Beer:** According to The Code of Hammurabi of ancient Babylonia (c. 1750 B.C.) a merchant could be put to death for diluting beer. Since there is nothing whatsoever funny about this fact we've decided to switch subjects to this charming nature story: A gorilla walks into a bar, pulls up a stool, and orders a beer. The bartender pours him a tall, frothy mug and says "That'll be eight bucks." As the gorilla is paying for his beer, the bartender adds "You know...we don't get many gorillas in here." To which the gorilla replies, "At eight bucks a beer, it's no wonder..."



**#6 Institution of Marriage Inexorably Linked to Beer** In eleventh-century England, a bride would serve ale to her wedding guests in exchange for donations to the newlyweds. The brew, known as Bride Ale, not only gave birth to the word "bridal," but seems to us to be convincing, historical proof that the institution of marriage has always been between a man, a woman, and a beer.



**#5 Happy Hour:** In olde England, city pubs paid a government tax known as a "scot" for serving beer. Thrifty beer lovers who left town to drink at rural pubs were said to be drinking "scot free". Your *QwikConnect* editors

were shocked to discover this fact as we had always assumed that drinking "Scot free" meant ditching Dougie at the hotel before we headed out to the bars.



**#4 Origin of the Six-Pack:** The first six-pack of beer was produced by the Pabst Brewery in the 1940s. The brewery conducted numerous studies, which found six cans were the ideal weight for the average housewife to transport home from the store. W.C. Fields might have been contemplating this very fact when he admitted, "a woman drove me to drink and I didn't even have the decency to thank her."



**#3 Congregationalist Beer Run:** According to a diary entry from a passenger on the Mayflower, the pilgrims chose to make their landing at Plymouth Rock, rather than continuing on to their original destination in Virginia, because they had run out of beer. We believe history also records they (thankfully) discovered a 7-11 run by a Patuxet Indian who supplied the pilgrims with enough turkey jerky and beer to last them through the winter.



**#2 Who Drinks the Most Beer?:** Frankly, most cultures in the world can claim bragging rights for national beer consumption. But when it comes to individual efforts, no one can top Konishiki—reputed to be the world's largest sumo wrestler at 625 pounds—who once consumed 100 glasses of beer and 70 pieces of sushi at one sitting. *Gottsu an desu!*



**#1 God, Country and Pale Ale:** We'll end this lighthearted salute to Duke Wilhelm IV with a favorite quote from Benjamin Franklin who wisely observed, "Beer is proof that God loves us and wants us to be happy."



# Series 171 Latching MicroStrip

## Need To Upgrade Your Poor-Performing COTS Connector for Ruggedized Performance? The Glenair Latching MicroStrip is the Answer

Series 171 MicroStrips are intended for high-reliability board-to-wire I/O and wire-to-wire applications. These nonenvironmental strips are typically used inside ruggedized equipment where moisture ingress is not a factor. The MicroStrip connector provides significant advantages compared to commercial-grade headers and jumpers. The rugged, high force twistpin contact accepts up to #24 gage wire, the current rating is 3 Amps, the voltage rating is 600 Vac, and the temperature rating is -55°C to +150°C. The Series 171 strip connector meets all applicable requirements of MIL-DTL-83513. Choose solder cup, pre-wired, or printed circuit board versions. A stainless steel latch provides secure coupling.

### PRODUCT FEATURES

- ◆ High Reliability TwistPin Contact System
- ◆ #24-30 AWG Wire Size
- ◆ .050" Pitch Contact Spacing
- ◆ Solder Cup, Pre-Wired or PCB Headers
- ◆ 3 Amps, +150C, 600 Vac
- ◆ Stainless Steel Coupling Latch

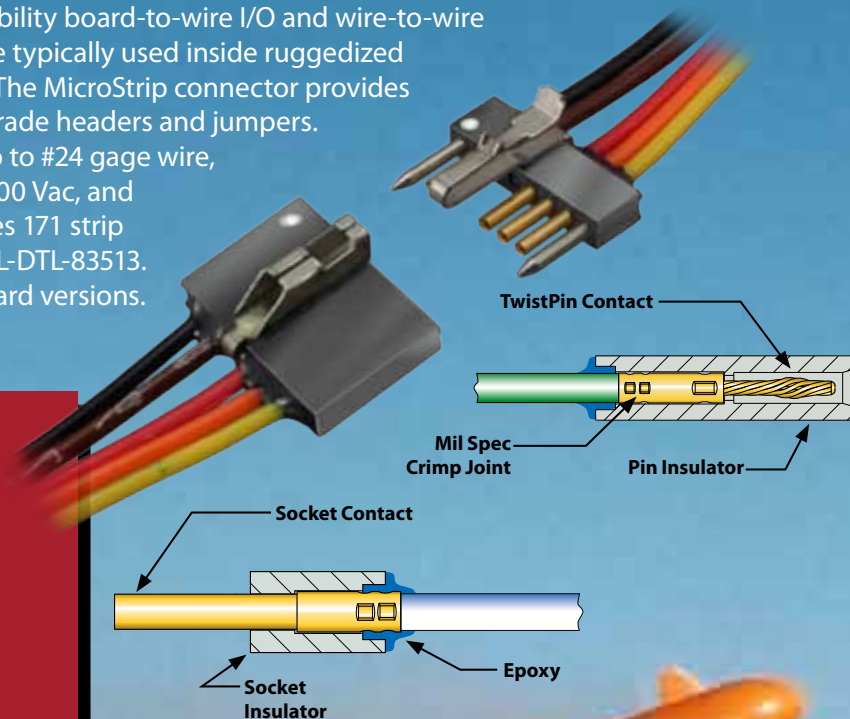

### About Spring Latches, Guide Pins and Mounting Holes

Optional stainless steel latch clips provide secure mating when subjected to shock and vibration. A single center latch is suitable for most applications (Fig. 1 and Fig. 2). Dual end latches are also available (Fig. 3). The spring latch is always installed on the socket strip (Fig. 1). The latch receiver is installed on the pin strip (Fig. 2). To unmate the connectors, simply press the release tab while pulling the connectors apart. MicroStrips are available with stainless steel guide pins. A single guide pin provides circuit polarization. A guide pin on each end (Fig. 2) helps to align connectors when mating and prevents damage to contacts. For most applications the preferred configuration is a single center latch with no guide pins. Mounting holes are now available (Fig.3). Attach strips to circuit boards with size 0-80 screws (customer-supplied).



**Figure 1**

**Socket Strip with Center Latch**  
Part Number 171-003-8S-6K7-18-PBCL

Spring latch installed in the center cavity of the socket MicroStrip. Ordering Code CL for Center Latch. This strip has 5 circuits plus one cavity for the latch and two for the guide pins, for a total of 8 cavities. Note the white paint dot on the insulator. This dot indicates position #1. The wire color code system is "10 Color Repeating". Wire #1 is black, followed by brown, red, orange, yellow, green, blue, violet, grey and white.

**Figure 2**

**Pin Strip with Center Latch and Guide Pins at Both ends.**  
Part Number 171-003-8P-6K7-18-PBCL

Spring latch installed in the center cavity and guide pins installed in end cavities. This strip has five electrical circuits plus two positions for guide pins and one position for the latch for a total of eight cavities. The stainless steel guide pins are installed into the end cavities of the socket strip. The end cavities of the pin strip are opened up to accept the mating guide pins.

**Figure 3**

**Right Angle PCB Header with End Latches and Mounting Holes.**  
Part Number 171-004-9P-.250-BLMH.

Latch clips installed into the end cavities of the MicroStrip. Ordering Code BL for Both end Latches. Note the mounting holes. These holes allow the strip to be attached to a circuit board. Each mounting hole requires three cavities. The board mount leads are formed into a single row on .050" centers.

### Materials and Finishes

Contacts	Copper alloy, 50 µinch gold plated
Insulators	Liquid crystal polymer (LCP)
Latch	Stainless Steel
Guide Pin	Stainless Steel
Potting Compound	Epoxy
Insulated Wire	Per MIL-W-22759/11 and /33
Solid Wire, PC Tails	Per A-A-59551, gold plated or tinned

### Specifications

Current Rating	3 Amps
Contact Resistance	8 milliohms maximum
Dielectric Withstanding Voltage	600 Vac sea level
Insulation Resistance	5000 megohms minimum
Operating Temperature	-55° C. to +150° C.
Shock	300 g.
Vibration	37 g.

### Why Choose TwistPins?

The Glenair TwistPin contact system provides a superior wire attachment compared to stamped contacts. This translates into lower long-term contact resistance—and it does so under extreme conditions of vibration, shock and high heat. Plus, TwistPin connectors offer design flexibility without the penalty of longer delivery, setup charges or minimum order quantities.





# Operation Semper Tan

## Glenair: The Only Interconnect System Supplier to Offer Our Military Customer a Complete “Desert Tan” Solution

Glenair now offers a complete range of interconnect component materials suitable for use in military applications that require (or would prefer) FED-STD-33446 Desert Tan colored and conductive parts over other available colors such as CAD green or black. Materials and components successfully developed by Glenair now include cable jacketing, shrink boots, composite connectors and accessories, junction boxes, fabric cable braid, convoluted tubing, and more. The materials are intended for use on military vehicles, equipment trailers, soldier systems and other ground-based or ground-deployed applications.

### OPERATION SEMPER TAN (DT) PRODUCTS

- ◆ Harsh Environment Cable Jacketing and Overmolding
- ◆ High-Temperature Heat Shrink Boots and Transitions
- ◆ Composite Thermoplastic Connectors and Accessories
- ◆ Rugged Fabric Cable Overbraid
- ◆ Annular Convoluted Tubing
- ◆ Corrosion-Proof Composite Junction Boxes
- ◆ Injection-Molded Cable Assemblies





# Eye-Beam Fiber Optics

## The Revolutionary New Expanded Beam Fiber Optic Connection System From Glenair

### PRODUCT FEATURES

- ◆ High-Performance Floating GRIN Lens Expanded Beam Genderless Termini
- ◆ Optional Integrated Contact Retention Clips
- ◆ Pre-Terminated Ceramic Ferrule
- ◆ Precision Stainless Steel Alignment Sleeve
- ◆ Field Cleanable
- ◆ Small Form Factor Resists Vibration and Shock

Switching from electrical to fiber optic connection systems delivers significant performance gains in bandwidth, transmission speed, as well as immunity to EMI/RFI. However, this improved performance comes with a price. Conventional butt-joint fiber optic termini are prone to performance degradation as a result of surface contamination and inappropriate user handling. The Glenair Eye-Beam fiber optic terminus, a GRIN lens equipped expanded beam optical transmission system that delivers outstanding performance and eliminates maintenance cycles, solves this problem. The low insertion loss Eye-Beam offers comparable performance to standard butt joint termini, but in a package that's built to withstand rugged use and frequent mating/de-mating in field conditions.

The Glenair Eye-Beam contact utilizes an innovative free floating expanded beam lens and ultra high precision ceramic alignment sleeves as well as custom designed nickel alloy terminus bodies to ensure perfect alignment of optical signals and optimal optical performance. Best of all, the Eye-Beam can be integrated into virtually any circular or rectangular connector package.





# Do-Drop-In Adapters

## The Composite Swing-Arm Connector Clamp with Modular Inserts

This version of the popular Swing-Arm Strain-Relief Clamp features a banding insert that makes termination of EMI shielding a snap! In assembly, the strain-relief portion of the clamp is run-up and staged out of the way on the cable. This allows the user to complete the termination of the braided shielding to the special Do-Drop-In insert banding device with relative ease—unconstrained by the limited working-room usually afforded by combined strain-relief/shield termination devices. The toothed insert device and the clamp are then drawn together and the assembly is threaded to the connector, creating a tight, reliable ground path. This revolutionary accessory design saves time and money, both in the management of SKU's and in assembly.



### PRODUCT FEATURES

- ◆ 627-184 Integrates Adjustable Swing-Arm technology with Conical Ring Termination
- ◆ 627-142 Integrates Band Termination
- ◆ 627-170 Integrates Knit Braid Termination

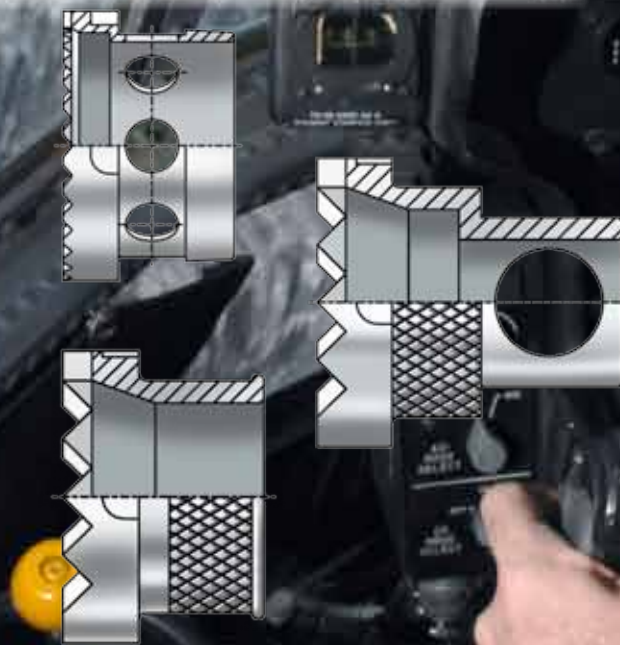



# Guardian Conduit System

## Terminating Economical Annular Conduit Has Never Been So Easy and Reliable. Introducing the Glenair "Guardian" Conduit System:

### *The Perfect Balance of Economy and Performance*

The Glenair Series 72 Guardian Conduit System permits you to accommodate last-minute engineering changes, and to quickly assemble conduit systems in a variety of individually specified configurations and lengths as they are needed—all without the use of any special tools or equipment. The system is available with a wide selection of annular type Kynar convoluted tubing configurations as well as a comprehensive selection of fittings, including metal and composite versions. All fittings come equipped with environmental o-rings and self-locking coupling nuts and are available in straight, 45° and 90° designs. A complete selection of conduit to connector adaptors, including EMI shield termination and shrink-boot adapters are supplied.

### PRODUCT FEATURES

- ◆ Economical, high-performance, high-temperature tolerance conduit system
- ◆ Unique design requires no tools for the termination of conduit to connector and transition fittings
- ◆ Innovative retention ring reliably captures and retains conduit in place
- ◆ All fittings supplied in either metal or composite with self-locking coupling nuts
- ◆ Available fittings include EMI shield termination and shrink-boot adapters

### *About Glenair's Series 72 Guardian Annular Convoluted Tubing*

Glenair offers Series 72 Annular Convoluted Tubing unshielded, or with a variety of braids to meet various electromagnetic shielding requirements. Type A is provided unshielded, Types B through F define standard combinations of braided Materials. Other combinations can be provided upon request.

The Tubing can be successfully utilized in applications ranging from industrial robotics and aircraft wire protection to high nuclear radiation applications. In fact, the radiation stability of Kynar®, combined with its chemical resistance, has resulted in successful use in plutonium reclamation plants. Note: Kynar tubing is generally supplied in black. Consult the factory for other available colors including new Desert Tan (DT).



# ArmorLite™ EMI Shielding

## Glenair Stainless Steel ArmorLite™ EMI/RFI Micro-Filament Shielding Saves Weight (and Money!) Every Time You Fly

ArmorLite™ is a highly conductive, lightweight nickel plated micro-filament stainless steel EMI braid. It offers an array of benefits including improved flexibility compared to standard plated copper braid, enhanced EMI/RFI electrical performance, and significant cost savings from reduced fuel consumption due to its reduced weight compared to conventional braided shielding. ArmorLite is ideally suited for high-temperature applications where weight reduction is a principal design requirement, but high-heat prevents the use of metal clad thermoplastic shielding such as Glenair AmberStrand.

### PRODUCT FEATURES

- ◆ Improved flexibility and flexure characteristics when compared to standard QQB575/A-A-59569 plated copper braid
- ◆ Enhanced EMI/RFI electrical performance (DC resistance 1 ohm/ft) when compared to plated non-metallic braid
- ◆ 90-95% optical coverage for optimum EMI shielding effectiveness and transfer impedance
- ◆ Lower in cost when compared to plated non-metallic EMI braid
- ◆ Available in braid sizes (nom. ID) from .062 to 2.0 inches
- ◆ 60-70% lighter than standard nickel plated copper braid
- ◆ Highly resistant to high temperatures



**Product Series**  
103 - Braided Shielding

**Dash Number**  
103 - 051 - 024

100% ArmorLite™  
Nickel-Clad  
Stainless Steel

Specify Length on Purchase Order

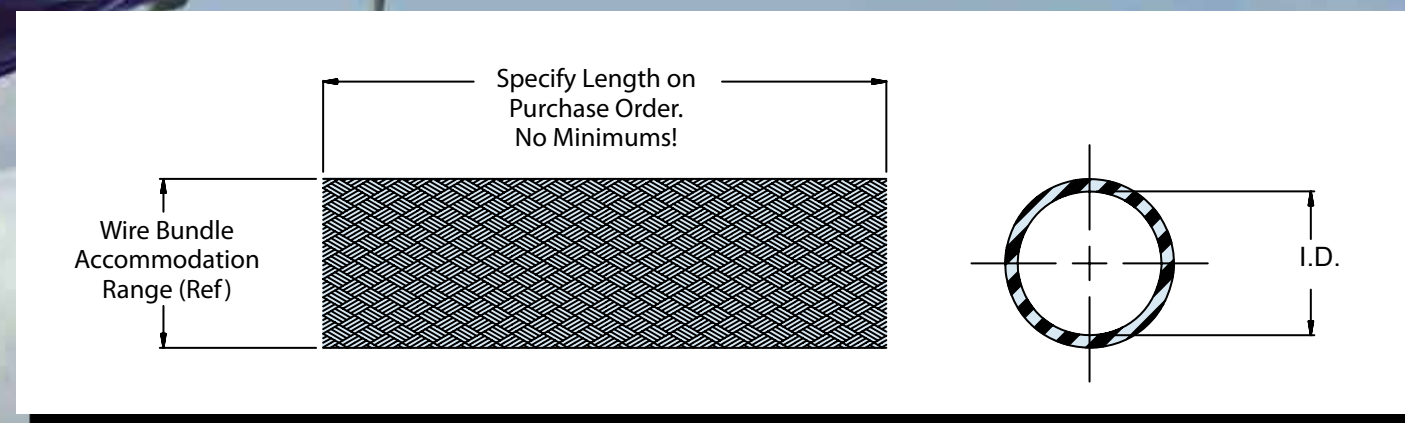



# Series 470-013 StarShield

## StarShield “Zero Length” Individual Shield Termination Backshell

The Glenair Series 470-013 StarShield “Zero Length” Individual Shield Termination Backshell offers optimal grounding of EMI/EMP braided shielding. The unique StarShield configuration completely eliminates “standing antenna” problems common with pigtail shield termination systems. The backshell utilizes familiar solder sleeve technology for fast and reliable termination of shielding—even with dissimilar wire types and gauges. The internal configuration of the StarShield features a tapered split-ring that fits snugly into the conically machined backshell. Tightening the coupling nut in place effects 360° grounding of all conductive surfaces. Standard configurations of the StarShield Backshell include banding and shrink-boot versions.

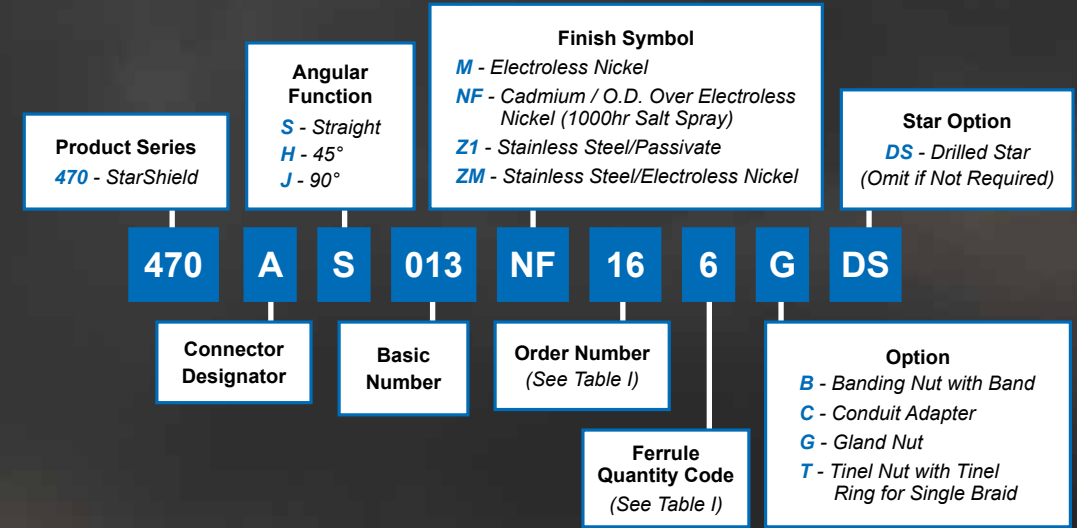
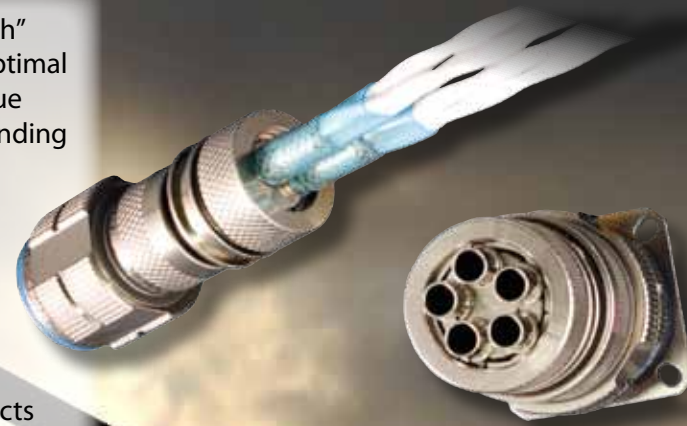

### PRODUCT FEATURES

- ◆ The unique Star-Shield configuration completely eliminates “standing antenna” problems common with pigtail shield termination systems.
- ◆ The backshell utilizes familiar solder sleeve technology for fast and reliable termination of shielding—even with dissimilar wire types and gauges.
- ◆ The internal configuration of the Star-Shield features a tapered split-ring that fits snugly into the conically machined backshell.
- ◆ Available fittings include EMI shield termination and shrink-boot adapters.



Pending

# MIL-PRF-28876 QPL Fiber Optics

## The Workhorse of Naval Fiber Optic Connection Systems: MIL-PRF-28876

### The Glenair MIL-PRF-28876 Fiber Optic Connector

The use of fiber optics in shipboard and ship-to-shore data transmissions is growing rapidly, and the tight-tolerance MIL-PRF-28876 interconnect has become the universal standard for Navy shipboard applications. Glenair's new offering—final QPL expected fourth quarter 2010—delivers all the necessary performance from precise optical alignment, to environmental protection, corrosion resistance and weight reduction. The Glenair MIL-PRF-28876 connector and terminus is specifically geared for upgrade and retrofit applications where extending system life-cycles and reducing cost of ownership are principle requirements. For more information, or for product samples, please consult the factory or visit us at [www.glenair.com](http://www.glenair.com).



### PRODUCT FEATURES

- ◆ Connectors Manufactured to the Complete Requirements of MIL-PRF-28876
- ◆ Qualified MIL-PRF-29504/14 and /15 Pin and Socket Contacts
- ◆ Plugs, Wall-Mount Receptacles, and Jam-Nut Mount Receptacles Available
- ◆ Multiple Shell Sizes and Insert Arrangements, Including 2, 4, 6, 8, 18 and 31 Layouts
- ◆ Singlemode and Multimode
- ◆ Corrosion-Resistant, Conductive NF Surface Finish
- ◆ Environmentally Sealed
- ◆ Same Day Availability

Type	Military Part Number	A Dia (Microns)	Typical Fiber Type
Pin Termini	QPL29504/14-4131	127.0/126.0	Multi Mode
	QPL-29504/14-4132	128.0/127.0	Multi Mode
	QPL-29504/15-4135	143.0/142.0	Multi Mode
Socket Termini	QPL-29504/15-4171	126.0	Multi Mode
	QPL-29504/15-4172	127.0	Multi Mode
	QPL-29504/15-4175	142.0	Multi Mode
Crimp Sleeve	-C	Add "-C" at end of part number for Crimp Sleeve, omit for none.	

Consult factory for additional sizes.

### How To Order: MIL-PRF-28876 Connectors

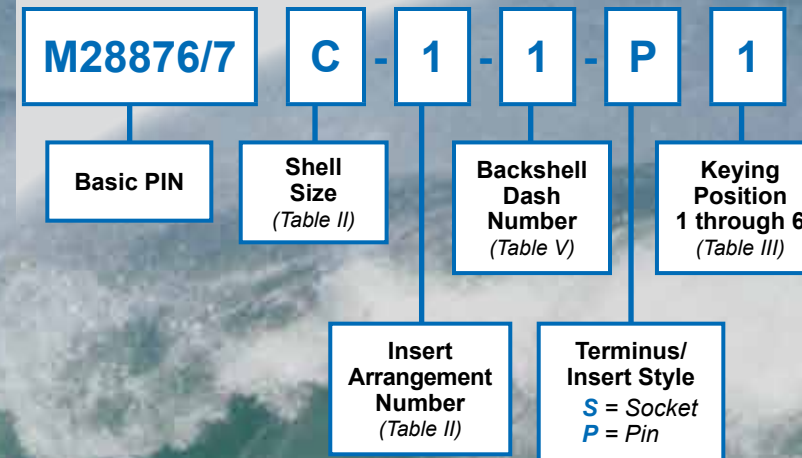

Shell Size	Mil-Spec Shell Size	Number of Terminus Cavities	Mil-Spec Insert Arrangement No.
11		02	
13	B	04	1
15	C	06 or 08	1 or 2
23		18 or 31	

Connector Type	Backshell Type	Connector Style	MIL-Spec Style Slash Number
Wall Mount Receptacle	None	03	M28876/1
	Straight	13	M28876/2
	45°	23	M28876/3
	90°	33	M28876/4
In-Line Receptacle	Straight	15	M28876/5
Plug	None	06	M28876/6
	Straight	16	M28876/7
	45°	26	M28876/8
Jam Nut Receptacle	90°	36	M28876/9
	None	04	M28876/11
	Straight	14	M28876/12
	45°	24	M28876/13
	90°	34	M28876/14

Backshell Designator	Max Allowable Cable Diameter by Shell Size			
	11	13	15	23
1	.250 (6.4)	.285 (7.2)	.500 (12.7)	.866 (22.0)
2	.346 (8.8)	.346 (8.8)	.250 (6.4)	1.000 (25.4)
3		.453 (11.5)	.375 (9.5)	.600 (15.2)



## The Red Queen Effect

Charles Lutwidge Dodgson, better known by the pseudonym Lewis Carroll, was an English author, mathematician and logician. His most famous writings are *Alice's Adventures in Wonderland* and its sequel *Through the Looking-Glass*, both of which are known as classic examples of "literary nonsense." Nonsense or not, Carroll was a keen observer of human nature and societal trends.

In *Through the Looking Glass*, a young and befuddled girl named Alice gets schooled by the Red Queen on the realities of her curious world: "In this place, it takes all the running you can do just to keep in the same place," she says. The Red Queen is saying that, like animals in nature, we all better wake up running if we want to survive another day. Charles Darwin observed, "It is not the strongest of the species that survives, nor the most intelligent, but the one most responsive to change." Which brings me to the point of this article: If we are destined to keep running just to survive—just to stay in the same place so to speak—wouldn't it be a good idea to learn how to run *smarter* instead of than just *harder*?

One of the ways we have determined to do this at Glenair is to devote significant resources to new product development. Now this may seem to be a counter-intuitive strategy, as the risks and costs of such work can be staggering. But it has been our experience that attempting to "stand pat" with our current line-up of people, processes and products, however successful they may be, will ultimately lead to stagnation and decay. In other words, if we fail to keep moving forward as an organization, we run the risk of getting eaten by some hungry competitor who has figured out how to run faster and smarter than we have.

New products, like the extravaganza of innovative designs in this special *Electronica 2010* Issue of *QwikConnect*, enable Glenair to address new interconnect challenges, new customer requirements, and new industry standards. Just imagine how fast we would have to run to earn a steady market share of business, let alone an increasing share, if we only had our original core products to sell! In today's business climate, standing pat for too long can equal suicide. As Eric Hoffer observed, "In a time of drastic change it is the *learners* who inherit the future. The *learned* usually find themselves equipped to live in a world that no longer exists." We hope our chosen behavior, particularly our willingness to keep innovating, confirms you have made the right choice in joining forces with Glenair in your own personal battle with the relentless forces of *The Red Queen Effect*.

### Publisher

Christopher J. Toomey

### Executive Editor

Marcus Kaufman

### Managing Editor

Carl Foote

### Deputy Editor

Mike Borgsdorf

### Art Director

Charles W. Belser

### Technical Consultant

Jim Donaldson

### Issue Contributors

Lisa Amling

Pat Banakis

Alex Boone

Ken Cerniak

Brendan Dempsey

Ty Geverink

Dick Holden

Guido Hunziker

Sheila Melcher

Greg Noll

Jim Plessas

Fred VanWyk

### Distribution

Terry White

*QwikConnect* is published quarterly by Glenair, Inc. and printed in the U.S.A. All rights reserved. © Copyright 2010 Glenair, Inc. A complete archive of past issues of *QwikConnect* is available on the Internet at [www.glenair.com/qwikconnect](http://www.glenair.com/qwikconnect)

### GLENAIR, INC.

1211 AIR WAY  
 GLENDALE, CA 91201-2497  
 TEL: 818-247-6000  
 FAX: 818-500-9912  
 E-MAIL: [sales@glenair.com](mailto:sales@glenair.com)  
[www.glenair.com](http://www.glenair.com)

