

QPL QUALIFIED

MIL-DTL-38999 Series III, Triple-Start Thread

D38999/23 jam-nut mount hermetic receptacle



SERIES III HERMETIC

QPL Part Number Development						
Sample Part Number	D38999/23 Y B 35 P N					
MIL-DTL-38999	D38999/23 = Jam-Nut mount receptacle					
Class	N = Hermetic, CRES, nickel finish, conductive, -65°C to 200°C Y = Hermetic, CRES, passivate finish, conductive, -65°C to 200°C H = Hermetic, CRES, passivate finish, conductive, -65°C to 200°C (space grade)					
Shell Size Code	A, B, C, D, E, F, G, H and J (per MIL-STD-1560)					
Insert Arrangement	Per MIL-STD-1560; See reference information section for details					
Contact Type	P = Pin, solder cup S = Socket, solder cup		X = Pin, eyelet Z = Socket, eyelet		C = Pin, PCB flex feedthrough D = Socket, PCB flex feedthrough	
Alternate Polarization	A, B, C, D, E, N = Normal					

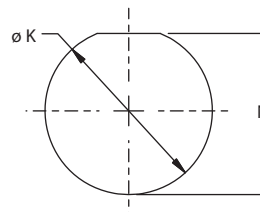
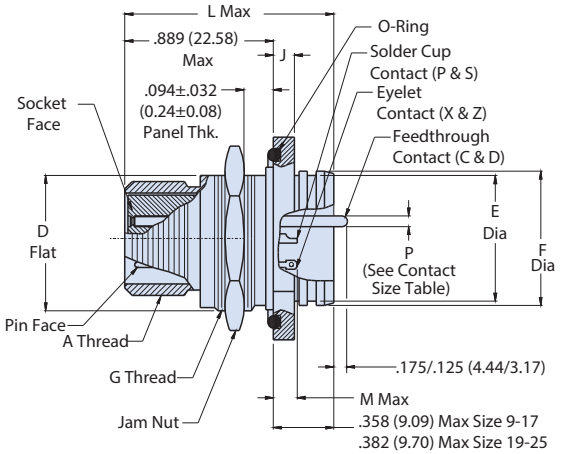
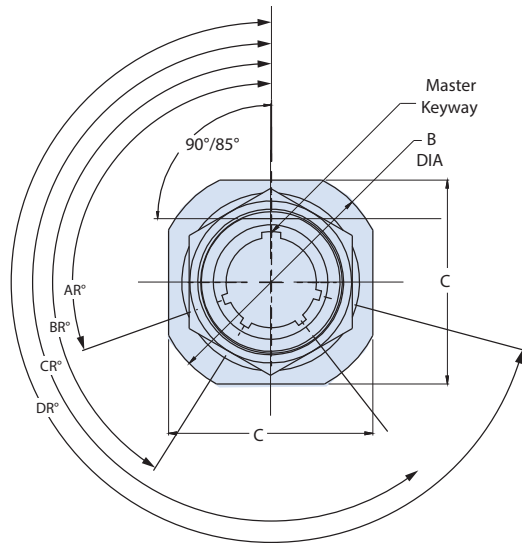

RECOMMENDED PANEL CUT-OUT

Wire Accommodation	
Contact Size	Wire Gauge
22D	#22 - #28
20	#20 - #24
16	#16 - #20
12	#12 - #14

Series III Alternate Keyway Polarizations																				
Shell Size Code	Shell Size	Key and Keyway ID Letter	AR° BSC	BR° BSC	CR° BSC	DR° BSC	Shell Size Code	Shell Size	Key and Keyway ID Letter	AR° BSC	BR° BSC	CR° BSC	DR° BSC	Shell Size Code	Shell Size	Key and Keyway ID Letter	AR° BSC	BR° BSC	CR° BSC	DR° BSC
A	9	N	105	140	215	265	B C D	11 13 15	N	95	141	208	236	E F G H J	17 19 21 23 25	N	80	142	196	293
		A	102	132	248	320			A	113	156	182	292			A	135	170	200	310
		B	80	118	230	312			B	90	145	195	252			B	49	169	200	244
		C	35	140	205	275			C	53	156	220	255			C	66	140	200	257
		D	64	155	234	304			D	119	146	176	298			D	62	145	180	280
		E	91	131	197	240			E	51	141	184	242			E	79	153	197	272

MIL-DTL-38999 Series III, Triple-Start Thread



233-100-H7 jam-nut mount hermetic receptacle

233-100-DH7 jam-nut mount hermetic receptacle with dual o-rings

SERIES III HERMETIC

COTS Part Number Development						
Sample Part Number	233-100-H7 Z1 11 -35 P N					
Series / Basic Part No.	233-100-H7 = Hermetic, jam-nut mount receptacle 233-100-DH7 = Hermetic, dual o-ring, jam-nut mount receptacle (Use mod code 1358 to select alternate o-rings)					
Material/Finish	ZL = CRES, nickel finish, conductive, -65°C to 200°C Z1 = CRES, passivate finish, conductive, -65°C to 200°C Z1S = CRES, passivate finish, conductive, -65°C to 200°C (space grade)					
Shell Size	9, 11, 13, 15, 17, 19, 21, 23, 25					
Insert Arrangement	Per MIL-STD-1560; See reference information section for details					
Contact Type	P = Pin, solder cup X = Pin, eyelet C = Pin, PCB flex feedthrough S = Socket, solder cup Z = Socket, eyelet D = Socket, PCB flex feedthrough					
Alternate Polarization	A, B, C, D, E, N (Normal)					

Additional material/finish options are available, consult factory for ordering information.

Dimensions							
Shell Size Code	Shell Size	A Thread -0.1P-0.3L-TS	B Dia	C A/F ±.015(0.4)	D Flat ±.005(0.1)	E Dia ±.012(0.3)	F Dia
A	9	0.625	1.201 (30.5) 1.177 (29.9)	1.063(27.0)	.650(16.5)	.602(15.3)	.653(16.6) .642(16.3)
B	11	0.750	1.386 (35.2) 1.362 (34.6)	1.252(31.8)	.750(19.1)	.724(18.4)	.775(19.7) .764(19.4)
C	13	0.875	1.512 (38.4) 1.488 (37.8)	1.374(34.9)	.937(23.8)	.850(21.6)	.905(23.0) .894(22.7)
D	15	1.000	1.638 (41.6) 1.614 (41.0)	1.500(38.1)	1.061(26.9)	.976(24.8)	1.031(26.2) 1.020(25.9)
E	17	1.187	1.764 (44.8) 1.740 (44.2)	1.626(41.3)	1.186(30.1)	1.102(28.0)	1.153(29.3) 1.142(29.0)
F	19	1.250	1.949 (49.5) 1.925 (48.9)	1.811(46.0)	1.311(33.3)	1.228(31.2)	1.278(32.5) 1.268(32.2)
G	21	1.375	2.075 (52.7) 2.050 (52.1)	1.937(49.2)	1.436(36.5)	1.350(34.3)	1.405(35.7) 1.394(35.4)
H	23	1.500	2.201 (55.9) 2.177 (55.3)	2.063(52.4)	1.561(39.6)	1.476(37.5)	1.531(38.9) 1.520(38.6)
J	25	1.625	2.323 (59.00) 2.299 (58.39)	2.189(55.6)	1.686(42.8)	1.602(40.7)	1.653(42.0) 1.642(41.7)

Contact Size	
FEEDTHROUGH CONTACT STYLE C AND D	
SIZES 10, 12 AND 16 .065 (1.7) .035 (0.9)	
SIZE 22D AND SIZE 20	
Contact Size	ø P
22D	.011 (0.28); .015 (0.38)
20	.024 (0.61); .028 (0.71)
16	.0635 (1.61); .0615 (1.56)
12	.095 (2.41); .093 (2.36)
10	.126 (3.20); .124 (3.15)

Dimensions (Continued)									
Shell Size Code	Shell Size	G Thread Iso Metric	J ±.008(0.2)	K Dia ±.005 (0.1)	L Max	M Max			N ±.005 (0.1)
						P & X	S & Z	#8 (All)	
A	9/09	M17 X 1.0-6g	.106 (2.7)	.698 (17.73)	1.150 (29.2)	.209 (5.3)	.232 (5.9)	.595 (15.11)	.658±.003 (16.71±.08)
B	11	M20 X 1.0-6g	.106 (2.7)	.830 (21.08)	1.150 (29.2)	.209 (5.3)	.232 (5.9)	.595 (15.11)	.766 (19.46)
C	13	M25 X 1.0-6g	.106 (2.7)	1.015 (25.78)	1.154 (29.3)	.201 (5.1)	.224 (5.7)	.590 (14.99)	.950 (24.13)
D	15	M28 X 1.0-6g	.106 (2.7)	1.140 (28.96)	1.154 (29.3)	.201 (5.1)	.224 (5.7)	.590 (14.99)	1.080 (27.43)
E	17	M32 X 1.0-6g	.106 (2.7)	1.265 (32.13)	1.154 (29.3)	.201 (5.1)	.224 (5.7)	.590 (14.99)	1.205 (30.61)
F	19	M35 X 1.0-6g	.138 (3.5)	1.390 (35.31)	1.185 (30.10)	.201 (5.1)	.224 (5.7)	.590 (14.99)	1.330 (33.78)
G	21	M38 X 1.0-6g	.138 (3.5)	1.515 (38.48)	1.185 (30.10)	.201 (5.1)	.224 (5.7)	.590 (14.99)	1.455 (36.96)
H	23	M41 X 1.0-6g	.138 (3.5)	1.640 (41.66)	1.185 (30.10)	.201 (5.1)	.224 (5.7)	.590 (14.99)	1.580 (40.13)
J	25	M44 X 1.0-6g	.138 (3.5)	1.765 (44.83)	1.185 (30.10)	.201 (5.1)	.224 (5.7)	.590 (14.99)	1.705 (43.31)

† Connectors ordered with "Z1S" include outgas processing to conform to outgassing requirements of D38999 Class H.