



# 240-083 HiPer-D® Filter Connector with Crimp Removable Contacts



D-Subminiature  
MIL-DTL-24308 Type

**Table II - Shell Size, Insert Arrangement, Contacts and Dimensions**

Shell Size - Insert Arrangement	Contact Size	Contact Qty	Shell Size	Contact Type	A ±.015	B ±.005	C ±.005	D ±.005	E ±.015	F Max	G Max
1S9	#20	9	1	pin	1.213 (30.8)	0.666 (16.9)	0.984 (25.0)	0.329 (8.4)	0.494 (12.5)	0.769 (19.5)	0.432 (11.0)
1H15	#22	15		socket	1.213 (30.8)	0.643 (16.3)	0.984 (25.0)	0.311 (7.9)	0.494 (12.5)	0.769 (19.5)	0.432 (11.0)
2S15	#20	15	2	pin	1.541 (39.1)	0.994 (25.2)	1.312 (33.3)	0.329 (8.4)	0.494 (12.5)	1.093 (27.8)	0.432 (11.0)
2H26	#22	26		socket	1.541 (39.1)	0.971 (24.7)	1.312 (33.3)	0.311 (7.9)	0.494 (12.5)	1.093 (27.8)	0.432 (11.0)
3S25	#20	25	3	pin	2.088 (53.0)	1.534 (39.0)	1.852 (47.0)	0.329 (8.4)	0.494 (12.5)	1.635 (41.5)	0.432 (11.0)
3H44	#22	44		socket	2.088 (53.0)	1.511 (38.4)	1.852 (47.0)	0.311 (7.9)	0.494 (12.5)	1.635 (41.5)	0.432 (11.0)
4S37	#20	37	4	pin	2.729 (69.3)	2.182 (55.4)	2.500 (63.5)	0.329 (8.4)	0.494 (12.5)	2.282 (58.0)	0.432 (11.0)
4H62	#22	62		socket	2.729 (69.3)	2.159 (54.8)	2.500 (63.5)	0.311 (7.9)	0.494 (12.5)	2.282 (58.0)	0.432 (11.0)
5S50	#20	50	5	pin	2.635 (66.9)	2.079 (52.8)	2.406 (61.1)	0.441 (11.2)	0.605 (15.4)	2.188 (55.6)	0.544 (13.8)
5H78	#22	78		socket	2.635 (66.9)	2.064 (52.4)	2.406 (61.1)	0.423 (10.7)	0.605 (15.4)	2.188 (55.6)	0.544 (13.8)
6H104	#22	104	6	pin	2.729 (69.3)	2.212 (56.2)	2.500 (63.5)	0.503 (12.8)	0.668 (17.0)	2.312 (58.7)	0.606 (15.4)
				socket	2.729 (69.3)	2.189 (55.6)	2.500 (63.5)	0.486 (12.3)	0.668 (17.0)	2.312 (58.7)	0.606 (15.4)

**Table VI - Dimensions**

Shell Size	A +.005 -.000	B	C +.005 -.000	D +.005 -.000	E +.005 -.000
1	.450	.984	.787	.409	.746
2	.450	1.312	1.111	.409	1.074
3	.450	1.852	1.653	.409	1.614
4	.450	2.500	2.300	.409	2.262
5	.552	2.406	2.190	.521	2.159
6	.614	2.500	2.315	.583	2.288

**Table VII - Panel Dimensions**

Panel Code	Panel Thickness	F ± .005	G
R1	.031	N/A	N/A
R2	.047	N/A	N/A
R3	.062	N/A	N/A
R4	.093	.230	N/A
R5	.104	.230	.031
R6	.125	.230	.063
R7	.156	.230	.094

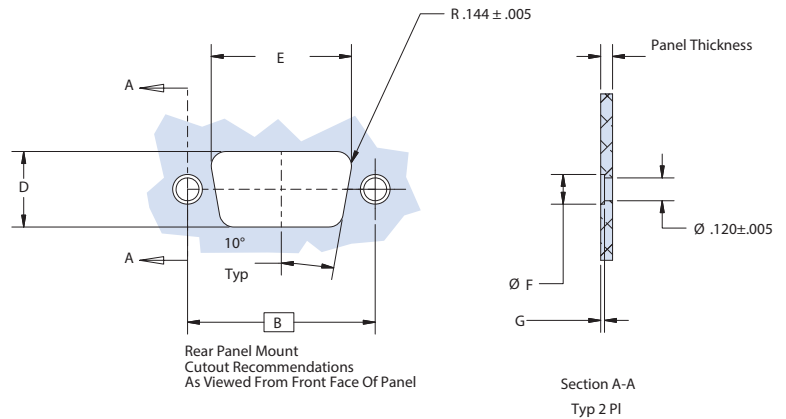
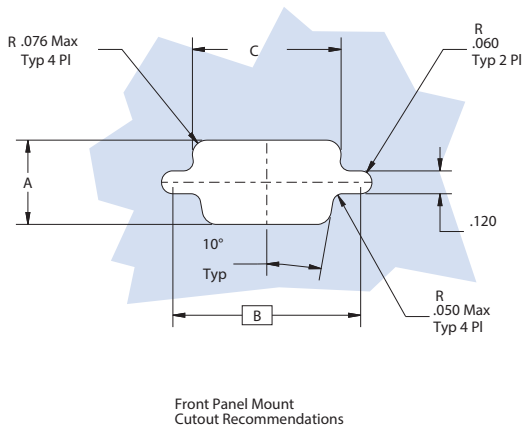

Dimensions in inches (millimeters) and are subject to change without notice.

E