



**180-150**  
**GFOCA Square Flange Mount Receptacle**  
**with Accessory Threads**  
**MIL-DTL-83526 Type, 4 Channel**



**MIL-DTL-83526 type hermaphroditic GFOCA square flange mount receptacle with accessory threads**

**How To Order**

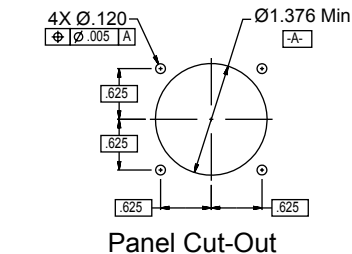
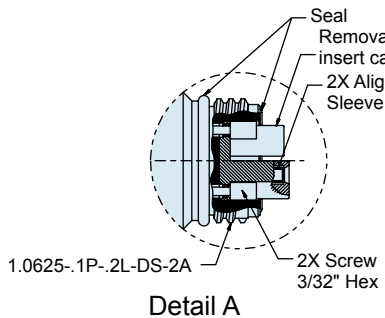
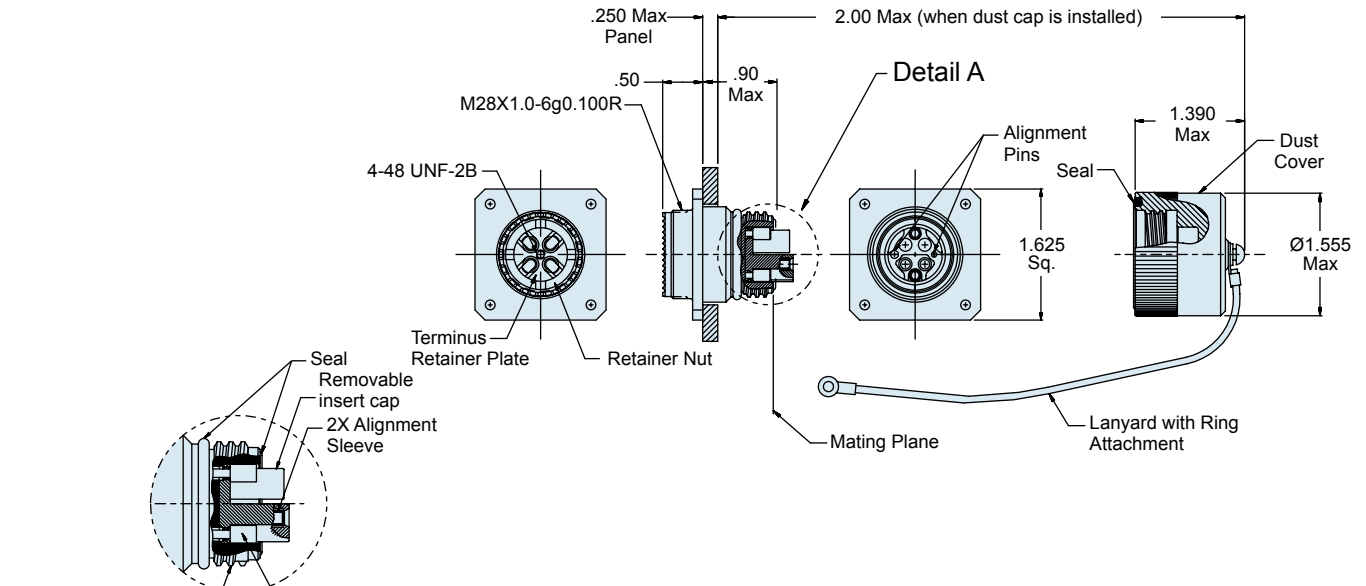
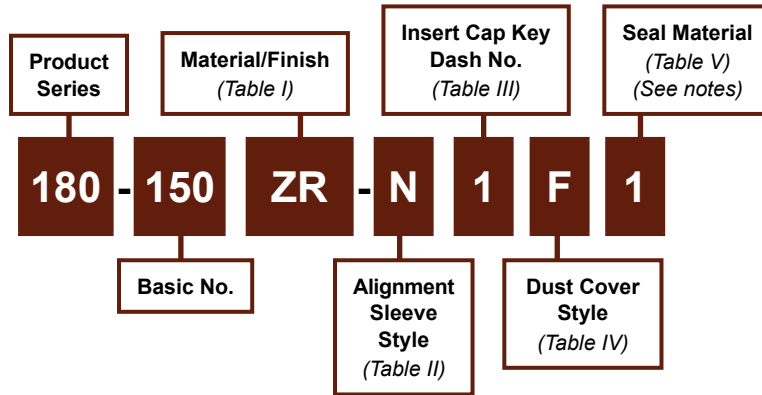

**Material and Finish**

External hardware: See Table I  
 Internal hardware: Al alloy/anodize  
 Misc. hardware: Stainless steel/passivate  
 Lanyard: Stainless steel/coated  
 Seals: See Table V

**Notes**

Connector assembly is designed IAW the interface requirements of MIL-PRF-83526/17 (Draft). Standard configuration is shown in sample part number. Accessory threads per shell size 19, D38999 Series III connector.

**180-150**  
**GFOCA Square Flange Mount Receptacle**  
**with Accessory Threads**  
**MIL-DTL-83526 Type, 4 Channel**

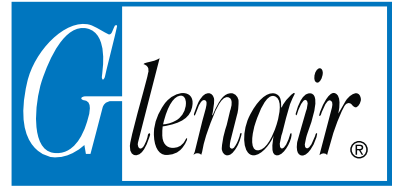

Table I: Material/Finish		
Code	Material	Finish Description
G2	Aluminum alloy	Hard anodize, gray
ZN		Zinc-nickel, olive drab
ZR		Zinc-nickel, black

Refer to Appendix for material/finish details

Table II: Alignment Sleeve Style	
Code	Style
N	None
Consult factory for additional options	

Table III: Insert Cap Key Configurations				
Dash No:	1	2	3	4
Config.	<p style="text-align: center;"><b>Key 1</b></p>	<p style="text-align: center;"><b>Key 2</b></p>	<p style="text-align: center;"><b>Key 3</b></p>	<p style="text-align: center;"><b>Key U (universal)</b></p>

Table IV: Dust Cover Style	
Code	Style
F	Female
H	Hermaphroditic
N	None

Table V: Seal Material	
Dash No.	Seal material(s)
1	Fluorosilicone / Fluorosilicone panel seal
2	Fluorosilicone / Conductive fluorosilicone panel seal
3	EPDM / EPDM panel seal
4	EPDM / Conductive EPDM panel seal