



713-380

Hat Trick System

Y Transition for Direct Attachment of Series 74 Helical Convuluted Tubing

Hat Trick Y transition with banding platform and boot groove for direct attachment of Series 74 conduit



How To Order

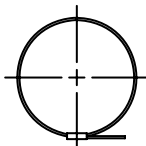
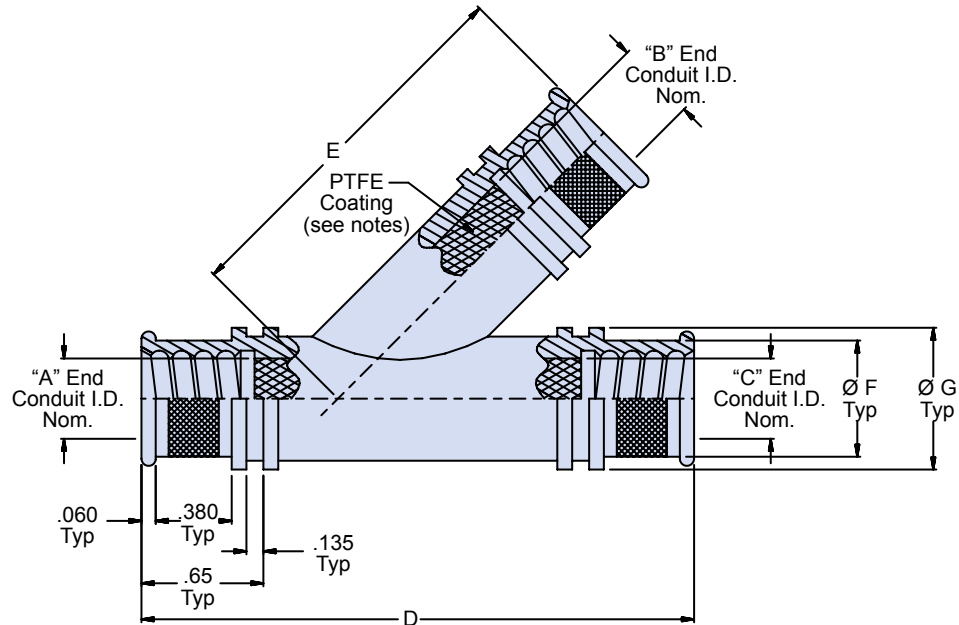
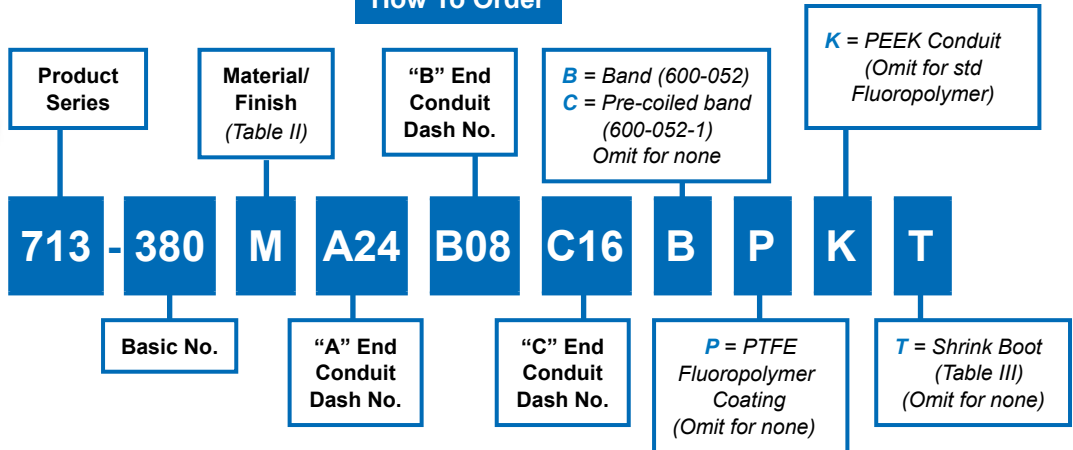

C option
Pre-coiled
band

Notes

- Internal surfaces coated with PTFE Fluoropolymer in area indicated, see P/N development.
- Overall dimensions will be determined by largest dash no. ordered, e.g. 713-380MA20B16C32 will have Dash No. 32 dimensions.

Material and Finish

- Transition: Table II (see P/N development)
- Band: SST/Passivate
- Shrink Boot: See individual dwg.

713-380
Hat Trick System
Y Transition for Direct Attachment of
Series 74 Helical Convuluted Tubing



Table III: Dimensions and Shrink Boot

Dash No	Conduit I.D. Nom	D Max	E Max	F Dia	G Dia	Shrink Boot Part Number
06	.188 (4.8)	2.66 (67.6)	1.52 (38.6)	.419 (1.6)	.481 (12.2)	770-001S103
09	.281 (7.1)	2.82 (71.6)	1.63 (41.4)	.513 (13.0)	.575 (14.6)	770-001S104
10	.312 (7.9)	2.82 (71.6)	1.69 (42.9)	.549 (13.9)	.611 (15.5)	770-001S104
12	.375 (9.5)	2.91 (73.9)	1.73 (43.9)	.609 (15.5)	.671 (17.0)	770-001S104
14	.437 (11.1)	3.06 (77.7)	1.83 (46.5)	.670 (17.0)	.732 (18.6)	770-001S104
16	.500 (12.7)	3.06 (77.7)	1.86 (47.2)	.749 (19.0)	.811 (2.6)	770-001S105
20	.625 (15.9)	3.38 (85.9)	2.08 (52.8)	.869 (22.1)	.931 (23.6)	770-001S106
24	.750 (19.1)	3.44 (87.4)	2.18 (55.4)	1.029 (26.1)	1.091 (27.7)	770-001S106
28	.875 (22.2)	3.75 (95.3)	2.51 (63.8)	1.172 (29.8)	1.234 (31.3)	770-001S107
32	1.000 (25.4)	3.97 (10.8)	2.57 (65.3)	1.320 (33.5)	1.382 (35.1)	770-001S107
40	1.250 (31.8)	4.28 (108.7)	2.90 (73.7)	1.664 (42.3)	1.726 (43.8)	770-001S108
48	1.500 (38.1)	4.92 (125.0)	3.19 (81.0)	1.957 (49.7)	2.019 (51.3)	770-001S108

Table II: Material/Finish

Sym	Material	Finish Description
M	Aluminum Alloy	Electroless Nickel
MT		Nickel-PTFE
NF		Cad/Olive Drab over Electroless Nickel (1000 hr. salt spray)
ZN		Zinc Nickel/Olive Drab over Electroless Nickel
ZNU		Zinc Nickel/Black over Electroless Nickel (1000 hr. salt spray)
Z1	Stainless Steel	Passivate
ZM		Electroless Nickel
ZW		Cad/Olive Drab over Electroless Nickel