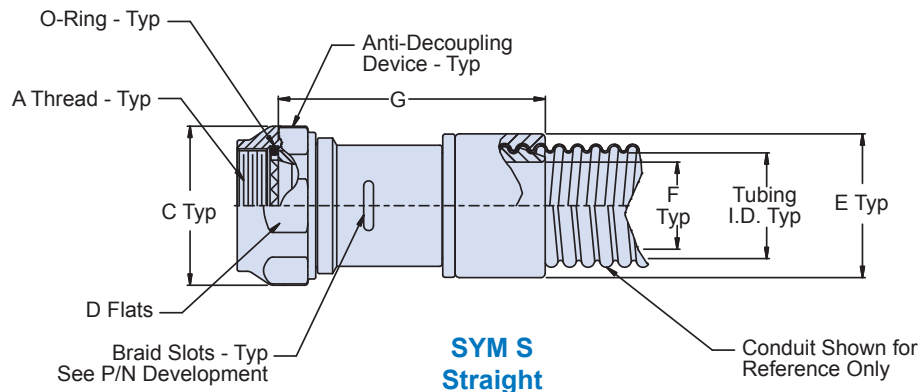
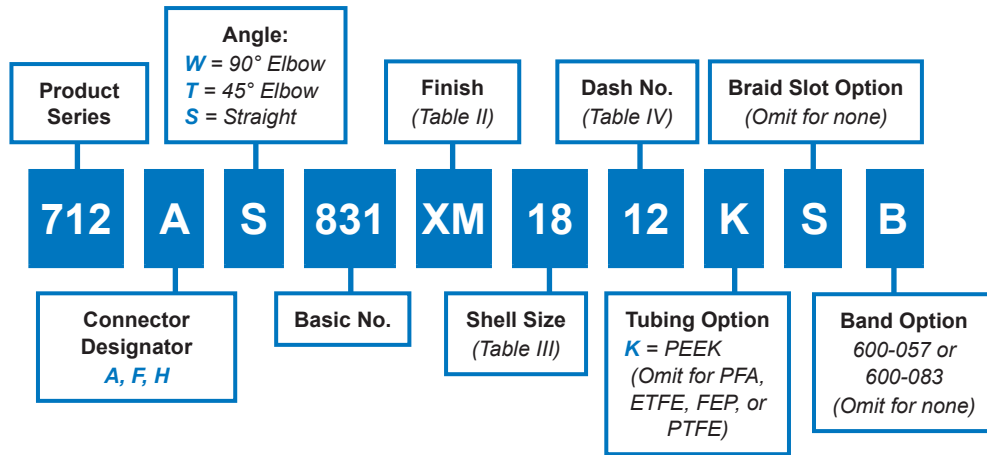

Composite AeroLite System convuluted tubing to connector backshell
How To Order

Material/Finish

- Adapters, Elbows: High grade engineering thermoplastic/See Table II
- Coupling Nuts, Ferrules: High grade engineering thermoplastic, black/no plating (XB)
- O-Ring: Fluorosilicone/NA (not supplied with Code A)
- Anti-Decoupling Device: Corrosion resistant material/N.A.
- Band: SST/Passivate

Notes

- Nom I.D. of PEEK tubing adapters are reduced by approximately .060 in.
- All coupling nuts and ferrules supplied unplated. Conduit termination platforms may also be unplated.
- Convuluted Tubing to be ordered separately, see 120-100, standard wall. Dash No. refers to Convuluted Tubing size.

712-831
AeroLite System - Composite
Convuluted Tubing to Connector Backshell
for Series 74 Helical Convuluted Tubing

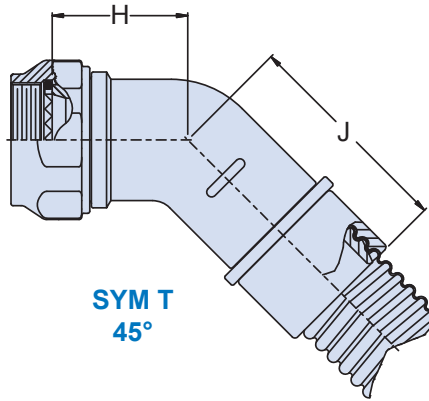
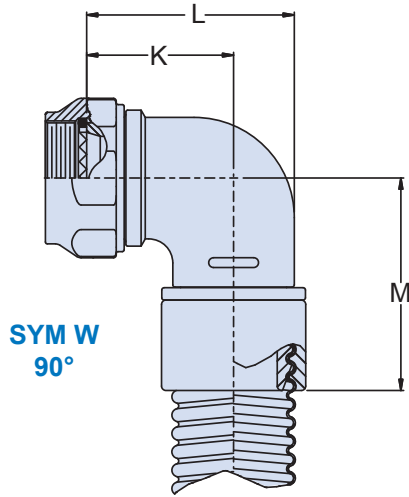

Table III: Connector Designators and Dimensions

Connector Designator A		Connector Designator F		Connector Designator H		Ø C Max	D Flats	
Shell Size	A Thread Class 2B	Shell Size	A Thread Class 2B	Shell Size	A Thread Iso Metric		Max	Min
08	1/2-20 UNF	08	7/16-28 UNEF	09	M12 X 1.0-6H	.830 (21.1)	.750 (19.1)	.736 (18.7)
10	5/8-24 UNEF	10	9/16-24 UNEF	11	M15 X 1.0-6H	.960 (24.4)	.875 (22.2)	.860 (21.8)
12	3/4-20 UNEF	12	11/16-24 UNEF	13	M18 X 1.0-6H	1.090 (27.7)	1.000 (25.4)	.980 (24.9)
14	7/8-20 UNEF	14	13/16-20 UNEF	15	M22 X 1.0-6H	1.220 (31.0)	1.125 (28.6)	1.100 (27.9)
16	1-20 UNEF	16	15/16-20 UNEF	17	M25 X 1.0-6H	1.350 (34.3)	1.250 (31.8)	1.224 (31.1)
18	11/16-18 UNEF	18	11/16-18 UNEF	19	M28 X 1.0-6H	1.480 (37.6)	1.375 (34.9)	1.348 (34.2)
20	13/16-18 UNEF	20	13/16-18 UNEF	21	M31 X 1.0-6H	1.620 (41.1)	1.500 (38.1)	1.469 (37.3)
22	15/16-18 UNEF	22	15/16-18 UNEF	23	M34 X 1.0-6H	1.750 (44.5)	1.625 (41.3)	1.581 (40.2)
24	17/16-18 UNEF	24	17/16-18 UNEF	25	M37 X 1.0-6H	1.890 (48.0)	1.750 (44.5)	1.690 (42.9)

Table II: Finish

SYM	Finish Description
XMT	Nickel-PTFE - Gray (1000 Hour Salt Spray)
XM	Electroless Nickel
XW	Cadmium Olive Drab Over Electroless Nickel
XB	No Plating, Black - Base Material Non-Conductive

Table III continued: Shell Size and Dimensions

Shell Size A,F	H	G Max	H Max	J Max	K Max	L Max	M Max	Dash No. Max
08	09	1.71 (43.4)	.796 (20.2)	1.261 (32.0)	.770 (19.6)	.958 (24.3)	1.493 (37.9)	09
10	11	1.71 (43.4)	.830 (21.0)	1.376 (35.0)	.832 (21.1)	1.082 (27.5)	1.555 (39.5)	12
12	13	1.76 (44.7)	.825 (21.0)	1.453 (37.0)	.894 (22.7)	1.207 (30.7)	1.667 (42.3)	20
14	15	1.76 (44.7)	.833 (21.1)	1.494 (38.0)	.957 (24.3)	1.332 (33.8)	1.730 (44.0)	24
16	17	1.86 (47.2)	.855 (21.7)	1.614 (41.0)	1.020 (25.9)	1.458 (37.0)	1.893 (48.1)	24
18	19	1.96 (49.8)	.865 (22.0)	1.721 (43.7)	1.082 (27.5)	1.582 (40.2)	2.055 (52.2)	28
20	21	1.96 (49.8)	.895 (22.7)	1.743 (44.3)	1.145 (29.1)	1.707 (43.4)	2.117 (53.8)	32
22	23	1.96 (49.8)	.935 (23.7)	1.784 (45.3)	1.207 (30.7)	1.832 (46.5)	2.180 (55.4)	32
24, 61	25	2.06 (52.3)	.965 (24.5)	1.910 (48.5)	1.270 (32.3)	1.958 (49.7)	2.343 (59.5)	40
28	25	2.06 (52.3)	1.013 (25.7)	1.945 (49.4)	1.434 (36.4)	2.215 (56.3)	2.405 (61.1)	40

Table IV: Dash No.

Dash No.	Tubing I.D. Nom.	ØE Max	ØF ± .015 Entry
06	.188 (4.80)	.580 (14.7)	.157 (4.00)
09	.281 (7.10)	.670 (17.0)	.250 (6.40)
10	.312 (7.90)	.710 (18.0)	.281 (7.10)
12	.375 (9.50)	.770 (19.6)	.344 (8.70)
14	.437 (11.1)	.830 (21.1)	.406 (10.3)
16	.500 (12.7)	.920 (23.4)	.469 (11.9)
20	.625 (15.9)	1.040 (26.4)	.594 (15.1)
24	.750 (19.1)	1.200 (30.5)	.714 (18.1)
28	.875 (22.2)	1.340 (34.0)	.839 (21.3)
32	1.000 (25.4)	1.500 (38.1)	.964 (24.5)
40	1.250 (31.8)	1.660 (42.2)	1.214 (30.8)