

HARSH-ENVIRONMENT STAINLESS STEEL/NICKEL Qualified MIL-DTL-24749 Rev. C Type IV



Mil-qualified for shipboard applications

QPL MIL-DTL-24749 REV. C TYPE IV GROUND STRAPS



Glenair MIL-DTL-24749 Rev C Type IV ground straps solve harsh-environment shipboard corrosion and electrical resistance problems with a unique 50% Stainless Steel 316L / 50% Nickel 200 36AWG blend braid, and passivated Stainless Steel lugs. These US Navy-approved ground straps are qualified to the rigorous standards of M24749, and are tested beyond the mil-spec to survive 1000 hours salt spray. Allowed usages for Type IV straps can be found in MIL-STD-1310H.

How To Order					
Sample Part Number	M24749	-IV	-B	-L	-H
Product Series	MIL-DTL-24749 Rev. C Type IV bond strap				
Bond Strap Type	IV = Flat CRES 316 / Nickel 200 braid with mounting lugs				
Standard Size Code	A = 6.0" length; .90" width, .406 H dia. D = 6.0" length; .90" width, .281 H dia. B = 12.0" length, .90" width, .406 H dia. E = 12.0" length, .90" width, .281 H dia. C = 18.0" length, .90" width, .406 H dia. F = 18.0" length, .90" width, .281 H dia. N = for non-standard sizes				
Non-Standard Length	Non-Standard length in inches (omit for standard sizes)				
Hole Diameter	For non-standard length Size Code N only: .406 = 13/32" hole diameter .282 = 9/32" hole diameter Omit for standard sizes				

- Meets the rigorous specifications of MIL-DTL-24749 Rev. C
- Tested to survive 1000 hours salt spray
- Unique Stainless Steel/ Nickel hybrid braid
- Available in six standard configurations, with non-standard length/lug size configurations available

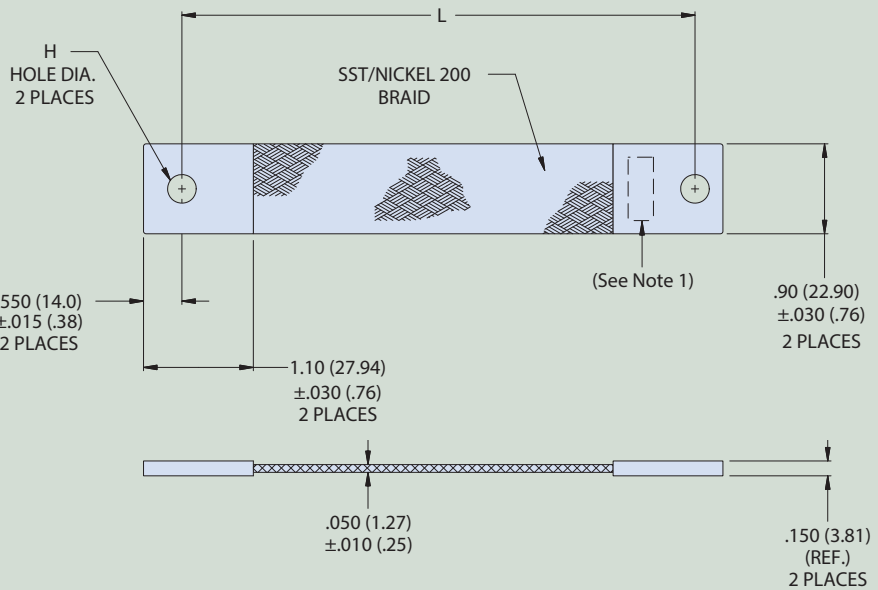

NOTES

1. Lugs are ink stamped or electro-etched per M24749 Rev. C Min. character height .06 (1.52)
2. Codes A – F are standard lengths. To order non-standard straps, enter Size Code **N**, enter **length** (in inches) in part number, and enter **0.406** or **0.281** for hole diameter.

MATERIAL/FINISH

Lugs - 316L Stainless Steel/Passivate
 Braid - 316L Stainless Steel 36 AWG, 50%; 200 Nickel 36 AWG, 50%



Glenair MIL-DTL-24749 Rev. C Type IV Stainless Steel/Nickel Ground Straps: US Navy qualified and tested to survive extreme environments

D