

Band-Master® ATS

Pneumatic Banding Tools

Pneumatic Banding Tools

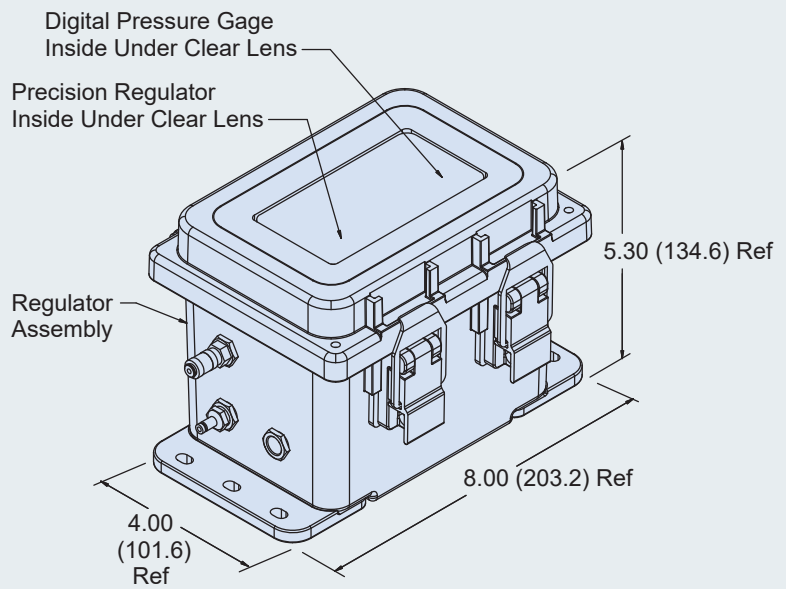
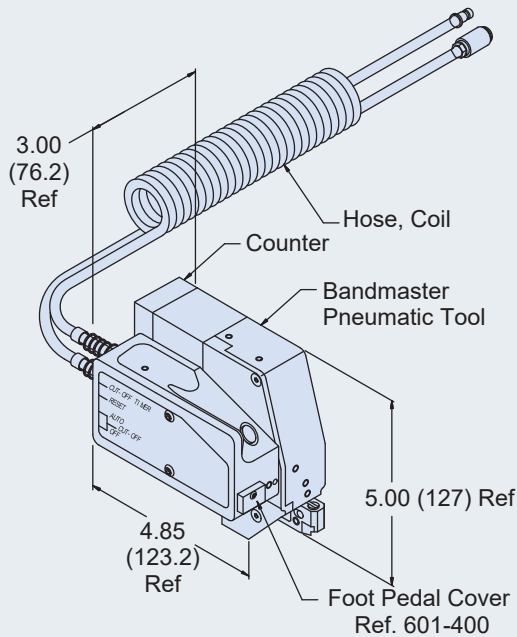

Pneumatic Banding Tool Replacement Blade and Knife	
Pneumatic Tool	Knife and Blade Kit P/N
601-106 Standard Pneumatic	601-330
601-110 Slim Standard Pneumatic	601-331
601-107 Micro Pneumatic	601-329
601-123 Micro Slim Pneumatic	601-328
601-130 Micro-Max Pneumatic	601-329
601-118 Nano Pneumatic	601-332

See tool descriptions on following page



Pneumatic Banding Tools

High-Volume Pneumatic Bench-Mount Units and Calibration Kits Available for Standard, Micro, Nano and Slim Band Termination Systems

601-106 Standard Pneumatic Banding Tool with Counter

The 601-106 Standard Pneumatic Banding Tool accommodates 601-005, 601-006, 601-040, 601-041, 601-049, 601-050, 601-052 and 601-054 standard quarter inch bands in a tension range of from 100-180 lbs. Calibrate at 150 ± 5 lbs for most shield terminations. Weight of the tool is 2.52 lbs (1.14 Kg); the control box weighs 3.51 lbs (1.59 Kg). Includes 601-400 foot pedal.

601-110 Slim Standard Pneumatic Banding Tool with Counter

The 601-110 Slim Standard Pneumatic Banding Tool accommodates 601-024, 601-025, 600-057 and 600-059 quarter inch Slim Standard bands. Approximate tension range of 30-80 lbs. Calibrate at 100 ± 3 lbs of linear pull. Weight of the tool is 2.52 lbs (1.14 Kg); the control box weighs 3.51 lbs (1.59 Kg). Includes 601-400 foot pedal.

601-107 Micro Pneumatic Banding Tool with Counter

The 601-107 Micro Pneumatic Banding Tool accommodates 601-024, 601-025, 601-060, 601-061, 601-064, 601-065, 600-057, and 600-059 eighth inch Micro Bands in a tension range of from 60 to 90 lbs. Calibrate at 80 ± 5 lbs for most shield terminations. Weight of the tool is 2.52 lbs (1.14 Kg); the control box weighs 3.51 lbs (1.59 Kg). Includes 601-400 foot pedal.

601-123 Micro Slim Pneumatic Banding Tool with Counter

The 601-123 Micro Slim Pneumatic Banding Tool accommodates 601-600, 601-601, 601-602, 601-603 Micro Slim bands. Approximate tension range of 60-90 lbs. Calibrate at 82 ± 3 lbs for most shield terminations. Tool Weight is 2.52 lbs (1.14 Kg); the control box weighs 3.51 lbs (1.59 Kg). Includes 601-400 foot pedal.

601-130 Micro-Max Pneumatic Banding Tool with Counter

The 601-130 Micro-Max Pneumatic Banding Tool accommodates 601-700, 601-701, 601-702, and 601-703 Micro-Max bands. Approximate tension range of 100-180 lbs. Calibrate at 132 ± 3 lbs for most shield terminations. Tool Weight is 2.52 lbs (1.14 Kg); the control box weighs 3.51 lbs (1.59 Kg). Includes 601-400 foot pedal.

601-118 Nano Pneumatic Banding Tool with Counter

The 601-118 Nano Pneumatic Banding Tool accommodates 601-570, 601-571, 601-572, and 601-573 Nano bands. Approximate tension range of 25-90 lbs. Calibrate at 50 ± 3 lbs of linear pull. Weight of the tool is 2.52 lbs (1.14 Kg); the control box weighs 3.51 lbs (1.59 Kg). Includes 601-400 foot pedal.