



**Band-Master® ATS
Nano Banding Tool
601-108
Operating Instructions**



Band-Master® ATS Nano Overview

- 1 Calibration Access Plug** (See Note 3)
- 2 Tensioning Lever:**
Squeeze with short gentle strokes to tighten band to the proper tension. Lever will lock to **3 Handle** with final full stroke.
- 4 Cut-Off Lever:**
Squeeze to lock band buckle and trim excess band material.
- 5 Calibration Counter**
- 6 Band Insertion and Release Lever:**
Depress lever to insert or release band from tool.
- 7 Serial Number**
- 8 Tension Release Lever**

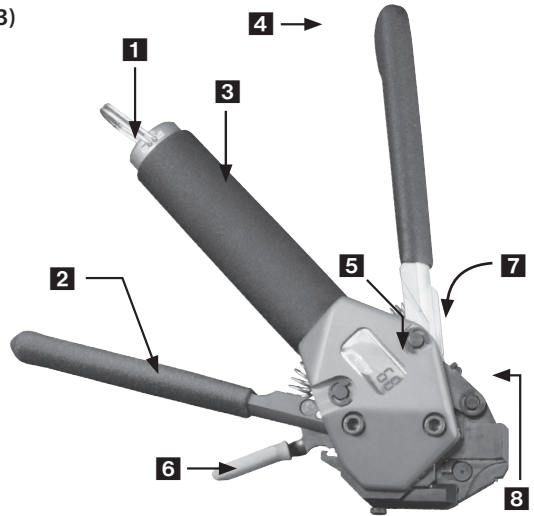

NOTES:

1. Use only genuine Band-Master® ATS bands. Other manufacturer's bands may damage tool.
2. Use only .075" wide bands with 601-108 tool.
3. Calibrate the Band-Master® Nano tool to 50 ±3 lbs.

Shield Termination Preparation Process

Step 1

Prepare Cable Braid for termination process

NOTE: banding must occur on an unfixtured cable assembly. Attaching a band to a firmly clamped cable will affect the applied forces and will also interfere with the cut-off operation. The cut-off operation causes a rotation of the band termination in order to lock the band.

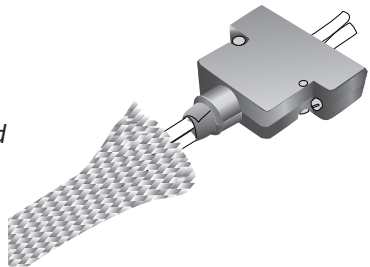

Step 2

Push braid forward over banding platform. Milk braid as required to remove slack and insure a snug fit around the shield termination area.

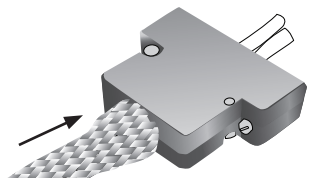

Shield Termination Assembly Process

Step 3

Double-coil the band prior to use:

IMPORTANT: Due to connector/adaptor circumference, it may be necessary to double-coil the band in place around the cable or retention area.

A. Insert leading edge of band through the buckle slot twice. (Bands must be double-coiled.)

B. Tighten the coil until the indicator mark (▷|) is approximately .250 inch (6.4mm) shy of the buckle slot (see illustration below). This will ensure sufficient band tail length for insertion into tool.

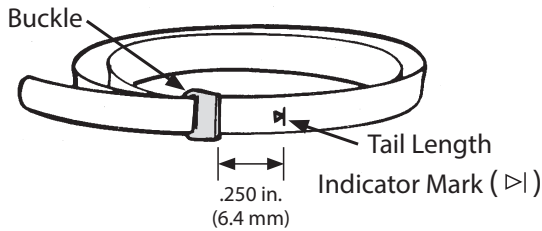

Step 4

Depress the band insertion and release lever (6), and insert the band into the front end opening of the tool, with the loop positioned outward as shown.

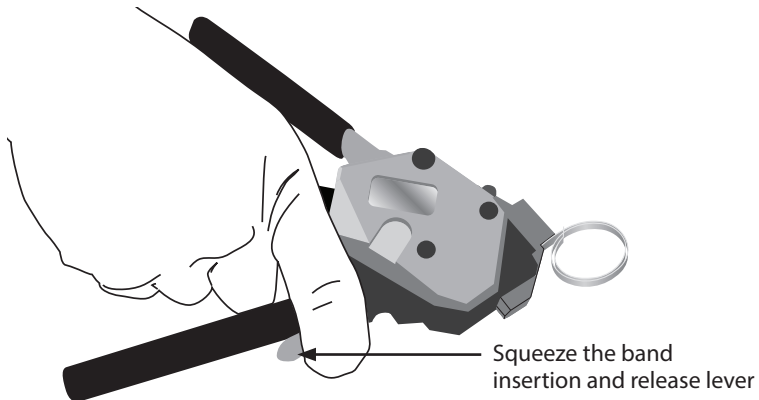

Shield Termination Assembly Process

Step 5

The band termination area on all backshells is wider than the band. Position the band near the rear lip of the banding platform, allowing room for buckle. For elliptical cable entries position the buckle off center of the peak of the circle. Failure to follow these guidelines will result in poor performance.

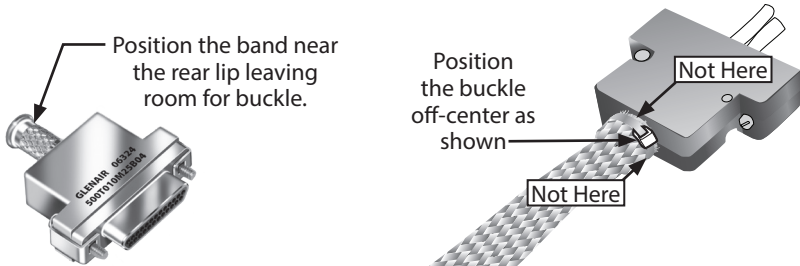

Step 6

Contract the band with the tensioning lever (2) using short, even strokes, as the band is firmly secured on termination area pull a full stroke to lock handle against the tool body indicating the band is compressed to the proper tension.

NOTE: *Overly rapid tightening of the band may result in uneven compression. If alignment of the band and shield is unsatisfactory, tension can be relaxed by pulling up tension lever (2) and pushing the tension release lever (8) forward on top of the tool. Make adjustments as necessary and finish tightening with tensioning lever (2) as described above. Instructional videos are available on the Glenair website:*

www.glenair.com/banding/

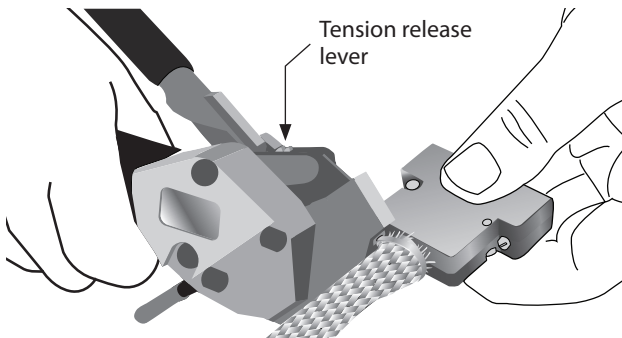

Shield Termination Assembly Process

Step 7

Complete the clamping process by depressing the cut-off lever (4), allowing band and cable to rotate slightly.

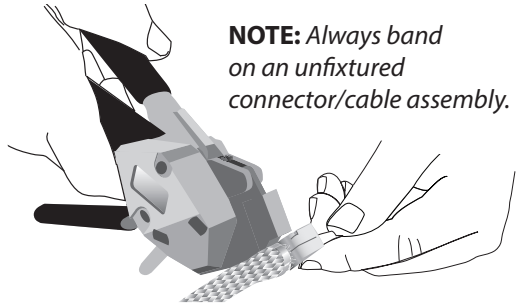

NOTE: Always band on an unfixtured connector/cable assembly.

Step 8

Pull up the release lever (6) to remove excess band for disposal.

Step 9

Trim away excess braid from the forward groove, particularly if a shrink boot is to be applied to the assembly.

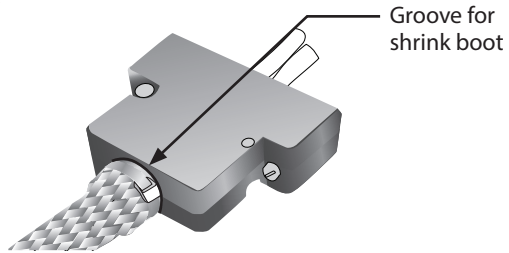

Step 10

Visually inspect shield termination for problems. If lip is damaged or missing, re-calibrate tool tension, check condition of cutter blade and knife, replace if worn or damaged.

NOTE: 1) If poor cutoff quality persists after knife and blade replacement, the tool must be serviced 2) Band can be removed by lifting the buckle with a screwdriver or diagonal cutters.

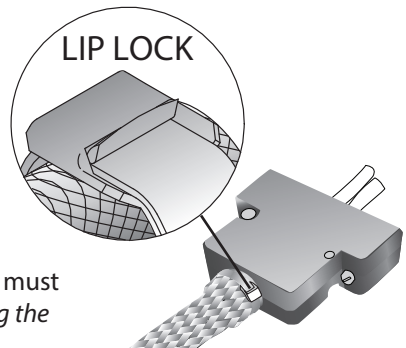

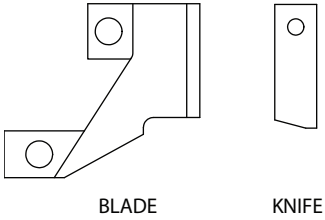

One piece knife and blade cutting heads must be replaced at the same time to ensure proper tension and buckle performance. Order cutting knife and blade kit when replacing worn blades.

601-332 Cutter
Knife and Blade Kit

One-Piece Knife and Blade Removal Procedure

Step 1

Remove two screws to release head assembly.

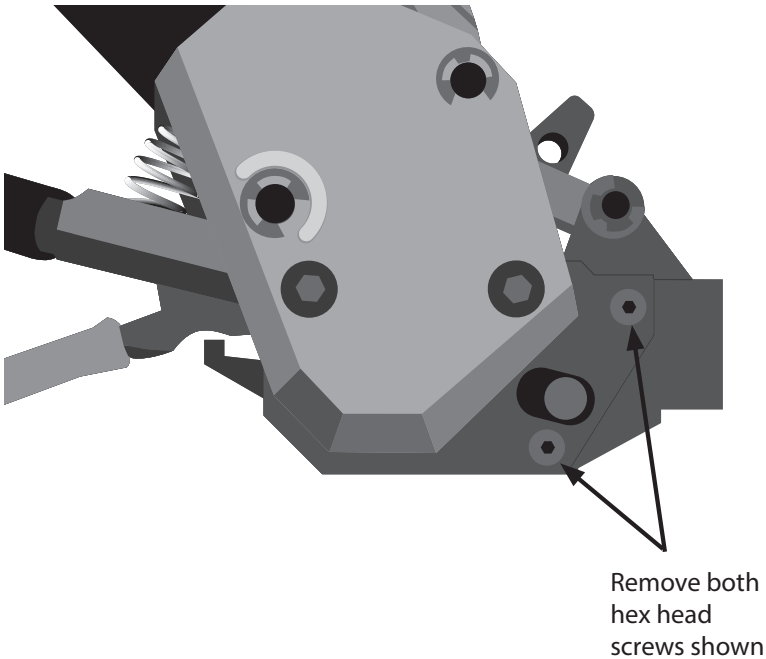

Step 2

Slide blade housing off to reveal knife.

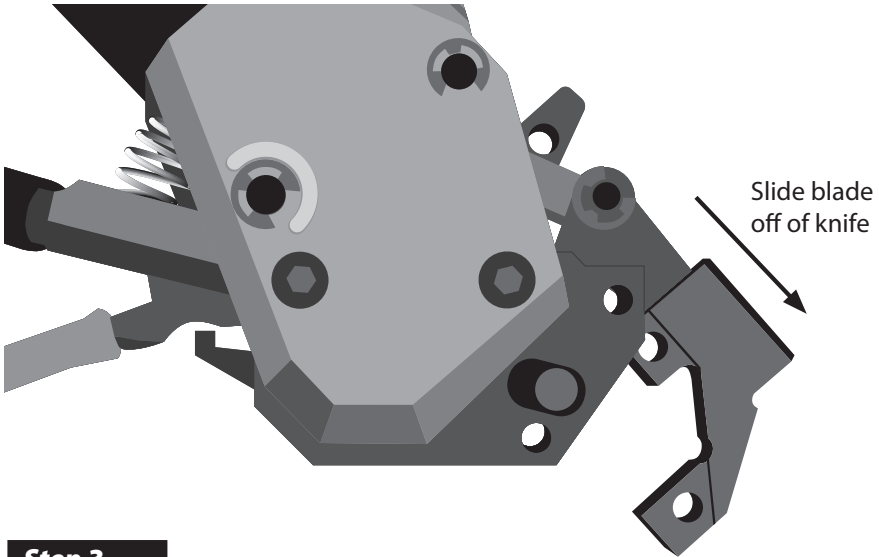

Step 3

Pull down at 45° angle to remove knife .

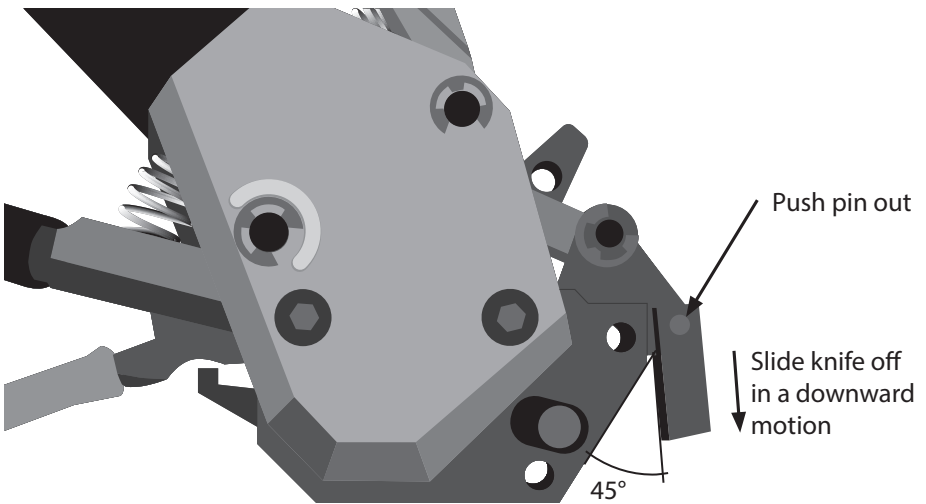

Counter Battery Replacement

1. Remove c-clip retaining washer and two SHCS screws from counter cover with 9/64 hex key.
2. Gently lift cover and counter assembly away from side of tool (do not pull wires)
3. Remove screw and washer indicated **1**
4. Pull up board, remove old battery and insert new 2025 (or equivalent) battery with (+) sign facing out (opposite to screen display)

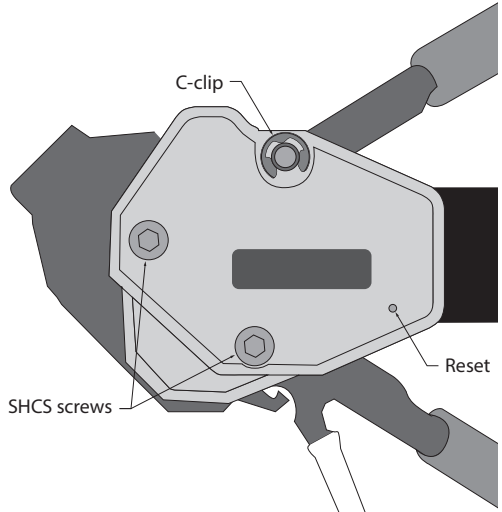

Counter Reset

1. Using a paper clip or other small object depress button on tool body located next to LCD window.

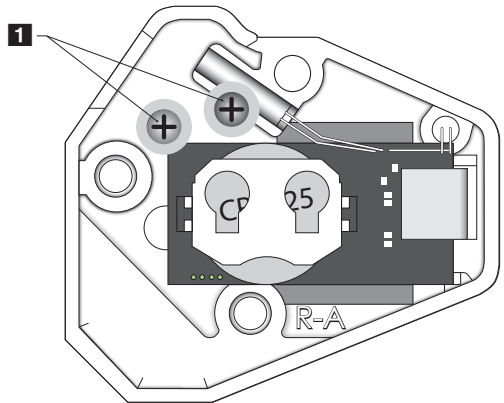

Tool Calibration

Band-Master® ATS tools are factory-calibrated and are supplied with a calibration certificate. Glenair recommends that tool calibration be checked after 500 terminations. Actual calibration interval can be determined by tool users. Glenair also provides calibration services. A portable kit is available for on-site calibration. Factory calibration value is 50 lbs \pm 3.

601-200 Digital Calibration Kit For Banding Tools

The 601-200 Digital Calibration Kit provides fast, easy, accurate calibration of all Banding Tools.

Kit includes the (1) 601-200-3 calibration device, includes meter, AC Adapter and USB cable (2) fifty 601-203 micro test bands, (3) fifty 601-202 standard test bands, (4) fifty 601-217 nano test bands (5) fifty 601-224 slim standard test bands (6) 601-205 calibration adjustment key, (7) tool adapter for 601-100 and 600-058 hand tools (installed), (8) 601-219 tool adapter for 600-067 and 601-104. (8) 601-220 tool adapter for 600-061, 600-068, 601-101, 601-105, 601-108. (9) 601-223 tool adapter for 601-109. (10) 601-221 adjustable mounting bracket for meter (11) 601-222 data logging software. Range of the calibration device is 45 to 180 lbs, and accuracy is calibrated to \pm 1 lb at factory. Head Unit Dimensions: 6.65 long x 2.47 wide x 2.83 high. Meter dimensions: 7.50 long x 3.30 wide x 1.28 high. Head Unit Weight: 3.2 lb. Meter Weight: 0.63 lb.

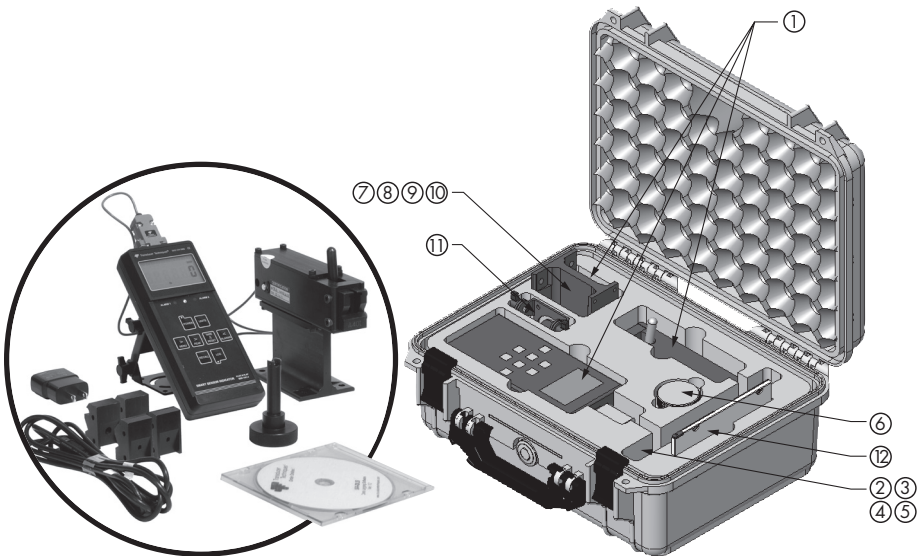

Pneumatic Tools for High Volume Production

Pneumatic **Band-Master® ATS** tools speed up band installation and reduce operator fatigue.

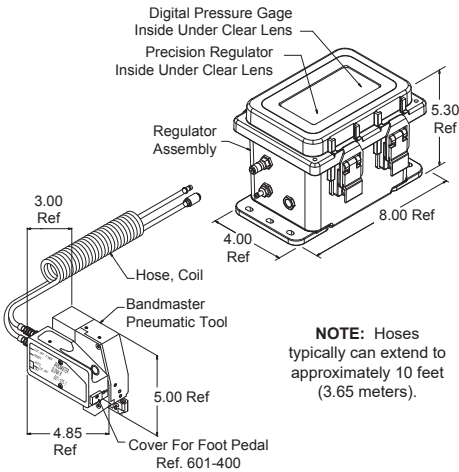

NOTE: Hoses typically can extend to approximately 10 feet (3.65 meters).

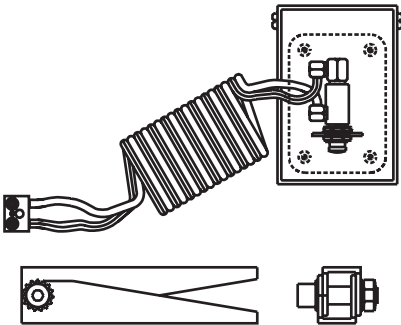

Band-Master® ATS Pneumatic Banding Tools

The Band-Master® ATS Pneumatic Banding Tools provide fast, easy band installation.

Weight of the tool is 2.52 lbs (1.14 Kg), control box weighs 2.74 lbs (1.24 Kg).

601-106 for use with standard bands.

601-107 for use with micro bands.

601-118 for use with nano bands

601-400 Foot Pedal Control for Pneumatic Banding Tools

free's both hands to help assure more accurate, reliable and faster shield terminations (included with pneumatic banding tool kits).

Tool Repair and Refurbishment

Glenair provides repair and refurbishment services for **Band-Master® ATS** tools. Typical services include calibration along with replacements of cutter knife and cut-off blade. Simply send the tool to Glenair:

ATTN: Customer Service
Glenair, Inc.
1211 Air Way
Glendale CA 91201



Visit the Glenair website for additional information on backshell assembly tools, banding tools and accessories:

www.glenair.com

Training videos on **Band-Master® ATS** termination procedures are available on the Glenair website:

<http://www.glenair.com/banding/>

Consult factory for additional recommendations for technical information on overall shields with distributed individual shields on common terminations.

| Band-Master® ATS Nano Band Selection | | | | |
|---|---------------|--------------------|-------------------|------------------------------|
| | Length | Part Number | | Accommodates Diameter |
| Bands | in./cm | Flat | Pre-Coiled | In./cm |
| Short Nano Band | 6.00 (152.4) | 601-500 | 601-501 | 0.6 (15.2) |
| Medium Nano Band | 9.00 (228.6) | 601-504 | 601-505 | 0.94 (23.9) |
| Long Nano Band | 14.00 (355.6) | 601-505 | 601-508 | 1.25 (31.75) |

| Band-Master® ATS Cut Off Knife and Blade Kit | | |
|---|--------------------|------------------------------|
| Description | Part Number | Replacement Parts For |
| Nano Cut-Off Knife and Blade Kit | 601-332 | 601-108 |

NOTE: Maximum application diameter for Nano bands is 1.25 in (31.75 mm).