

850-112
AS39029/64 Type
Thermocouple Pin Contact , Size #20



Special Purpose

MIL-DTL
24308

Series 28
HiPer-D

Thermocouple Pin Contact to Fit MIL-DTL-24308 and Series 28 HiPer-D connectors

Part Number	Material	Finish	Color Band
850-112-20-01	KN	None	Red
850-112-20-02	KP	None	None

Per AS39029 spec, the composition designations have been changed as listed below:
KN = Type K negative (formerly alumel) **KP** = Type K positive (formerly chromel)

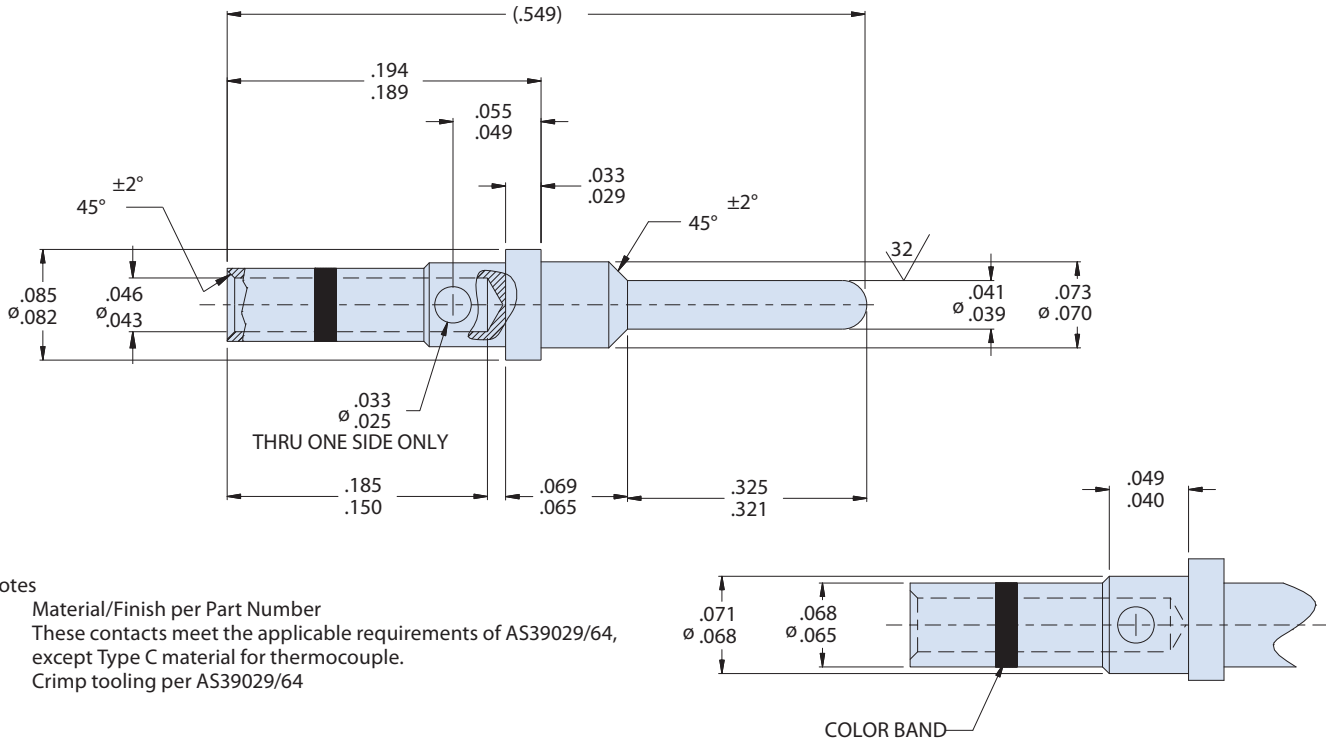

- Notes
1. Material/Finish per Part Number
 2. These contacts meet the applicable requirements of AS39029/64, except Type C material for thermocouple.
 3. Crimp tooling per AS39029/64